

VERANO

G L O B A L

Installation Manual
Of 4-pipe
Climaconvector
CVK4

Air vent

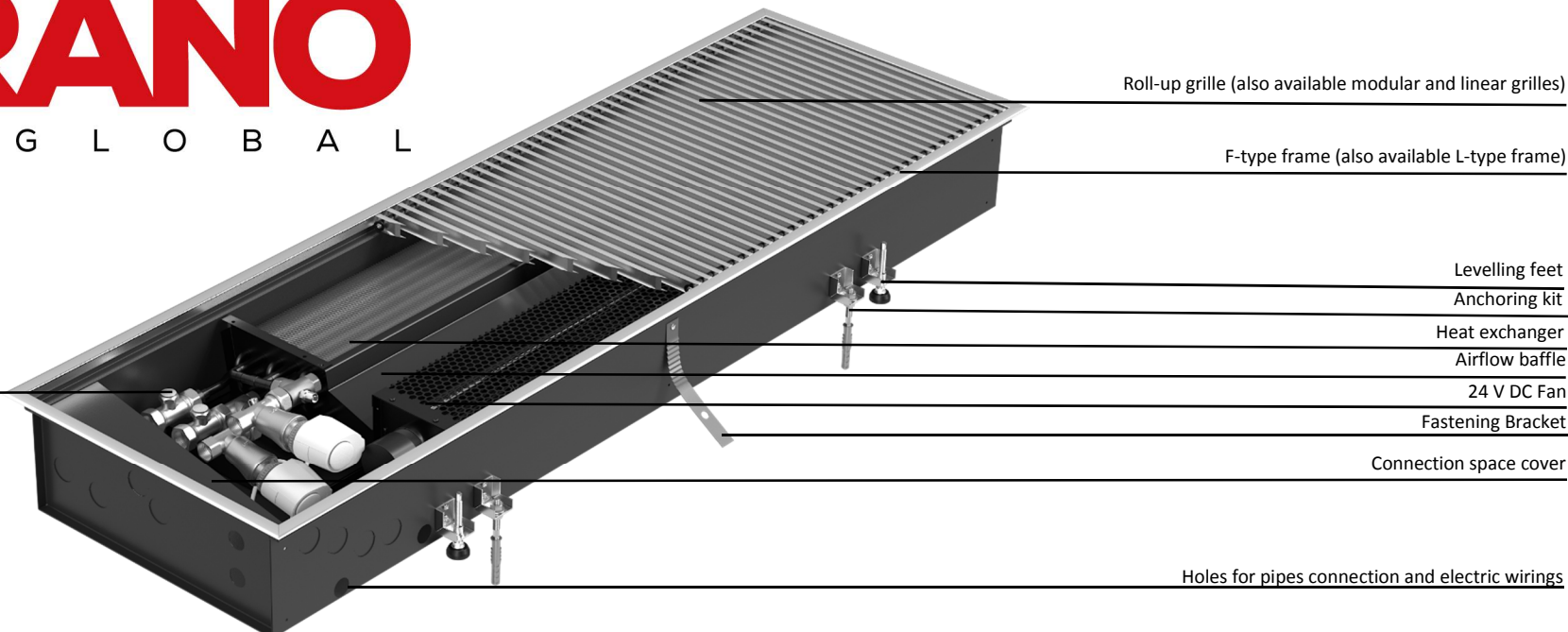

Connection – power supply and control

NOTE!

Fan electric connection:

- Red – positive + 24 V DC
- Black – negative (-) 24 V DC
- White – control voltage 0-10 V DC

NOTE!

0-10 V actuator electric connection:

- Black – positive + 24 V DC
- Blue – negative 24 V DC
- Red – control voltage 0-10 V DC

Recommended wire type: LIVCY

Allowed wire type: LIV

Electrical wires routing should be done in accordance with the applicable standards of the electrical industry.

The cable cross-section should be determined in accordance with electrical installation project based on the voltage drop calculations for the planned wires routing.

Frame type and heater height

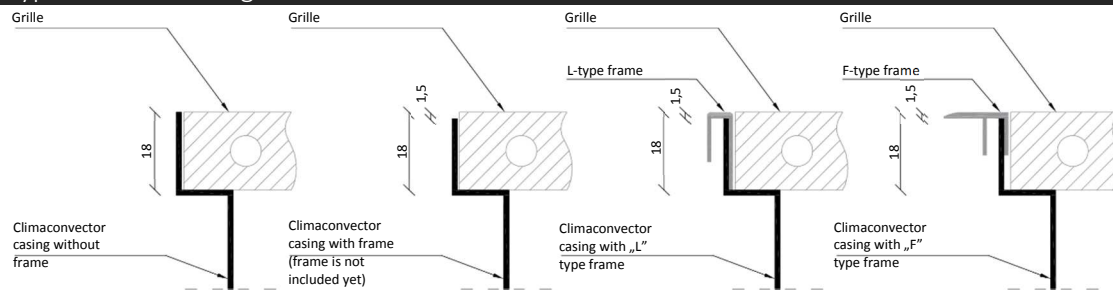

The height of the casing edge depends of the frame type. It is recommended to order frame with climaconvector or inform manufacturer about planned frame installation on later stage.

Casing edge for climaconvector without frame is 18 mm high – the same as the grille. Casing edge for climaconvector with frame is 16,5 mm high. Thanks to that, after installing the 1,5 mm frame, grille and frame are on the same level.

„F” frame should be installed on the casing after completing all installation and building works, according to the point ⑦ of this manual.

If you have any questions or doubts concerning installation works, please contact us:

VERANO OFFICE

Tel. +44 20 3290 0665

e-mail: export@v-k.pl

www.verano-global.com

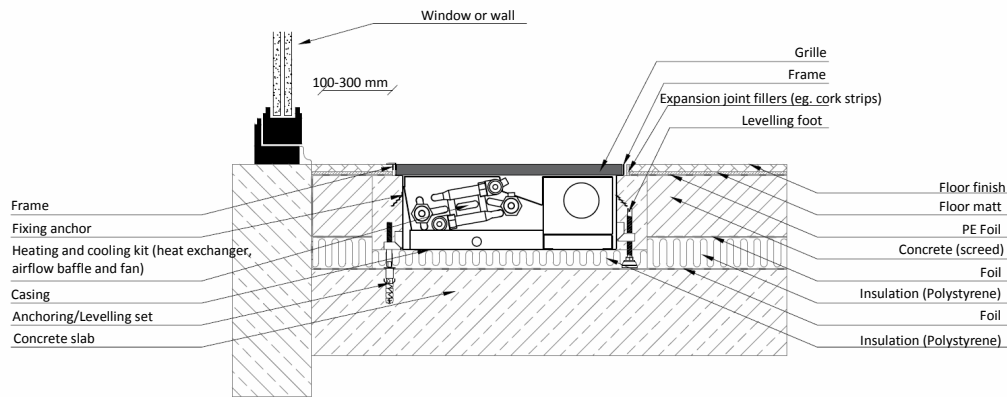

The example of CVK4 assembly

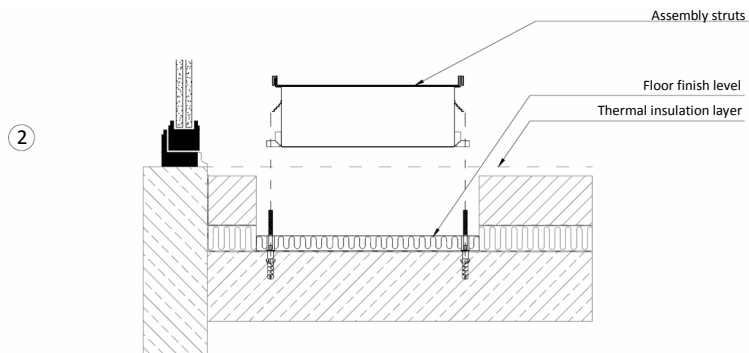

2. Heating fixing and thermal insulation

Prepare an appropriate holes for anchoring screws in concrete slab. Drill the holes on marked points and hammer the raw plugs into them. Place the thermal insulation on the concrete slab below trench casing. Remember to do the holes for fixing anchors and levelling feet in the insulation. The recommended thermal insulation is Polystyrene.

The thermal insulation layer under the casing should be done of materials of relative deformation factor not less than 70 kPa while compressive strength is at 10%.

The minimum insulation thickness should be not less than:

- 20 mm for climaconvectors installed in an upper levels (above the floor with central heating system),
- 140 mm for climaconvectors installed on the ground floor (Polystyrene declared properties: $\lambda = 0,004 \text{ W/m}^2\text{K}$, $U_{min} = 0,30 \text{ W/m}^2\text{K}$).

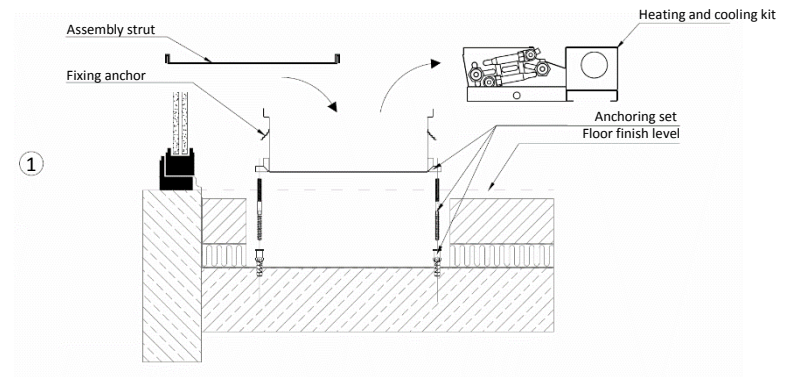

1. Prepare a duct for the climaconvector

Before starting the assembly works take out and secure the heating and cooling kit (heat exchanger, airflow baffle and fan). After that, install assembly struts on the casing.

Prepare a duct 100 mm wider and longer than climaconvector casing. For easy installation the depth of the trench should be planned in the way that the top of the grille is on the same level as floor finish level (take into account insulation in the bottom of the trench). Put the climaconvector casing in the center of the duct. Point the places for fixing anchors holes on the concrete. Put out the climaconvector casing of the trench.

NOTE!

Fans contaminated by dirt and dust while building or renovation works might cause damage of fans or louder fan work. Damage caused by fan contaminations are not covered by the warranty.

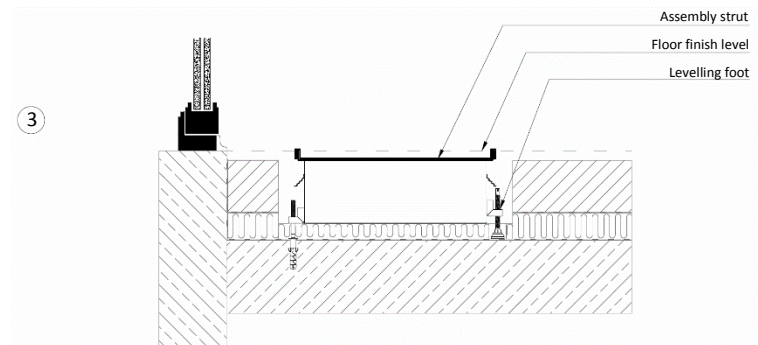

3. Install the climaconvector casing in the duct

Strike the holes for connection pipes of heating and cooling system, condensate drainage and for electric wires. You should strike holes in one side of the casing (longer or shorter side). For condensate drainage you can also use the hole in bottom side of the casing.

Put the casing with levelling feet in the duct. Levelling feet should be placed on the concrete slab. Do not install levelling feet on thermal insulation. Use the screwdriver to level the unit by levelling feet.

Screw the climaconvector casing using fixing anchor kits. Screw the M8 nut on the fixing anchor unit resistance is felt.

Fill the rest of the free areas between the climaconvector casing and thermal insulation with low expandable foam.

Leaving free space between the casing and thermal insulation can lead to increased volume of device.

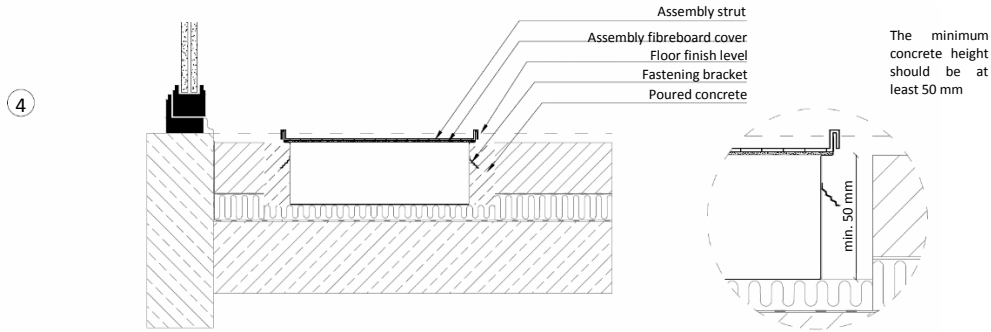

4. Do the hydronic and electric connections, pour the concrete around the casing

Install all pipes and electric wires. Secure the connections and all the holes in the casing by using low expandable thermal foam insulation. Make sure that the casing is properly settled in the trench and all connections are done. Make sure that assembly struts are installed on the top edge. One pouring the concrete put assembly fibreboard cover on the casing to avoid contamination inside the casing. Pour the concrete around the casing. The minimum height of concrete should be at least 50 mm.



Tray of CVK4 climaconectors are standardly equipped with a connection for connecting the grounding installation. To be used depending on local or special guidelines (the requirement to use PELV circuits for example).

According to the current regulations, low voltage devices (CVK4 climaconectors) should not be connected to the grounding of other installations.

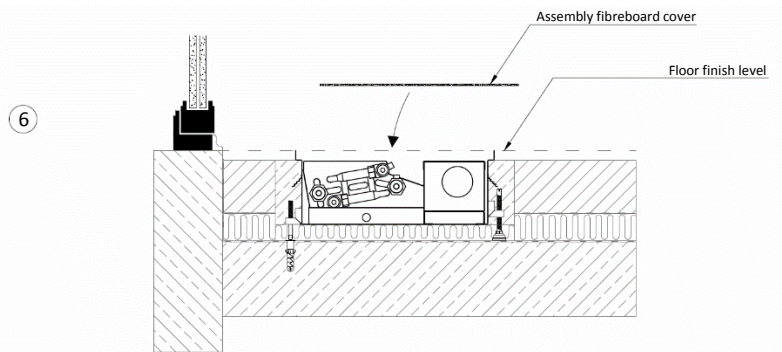

6. Do the hydronic and electric connections to the heating and cooling kit

Install valves and actuators (if required) on the pipes of heat exchanger. Connect the pipes to the valves. Supply pipe is to be connected to the heat exchanger pipe with air vent. Connect electric wires to the fan. Use the electric scheme to do the wiring for the actuator and controls.

Carry in the tightness test for hydronic connections.

After completing installation works, cover the climaconvector with the assembly fibreboard cover to avoid contamination of fan and heat exchanger with dust of the rest of building works. Damage caused by the heating and cooling kit contamination is not under warranty.

The correct work of the installation requires the appropriate settings to be made on the pressure independent control valves (PICV).

The drawing of the setting has been included on the last page. The selected valve setting should match the value presented in the project. In the absence of information the valve setting should be selected according to the design flow of the medium through the device.

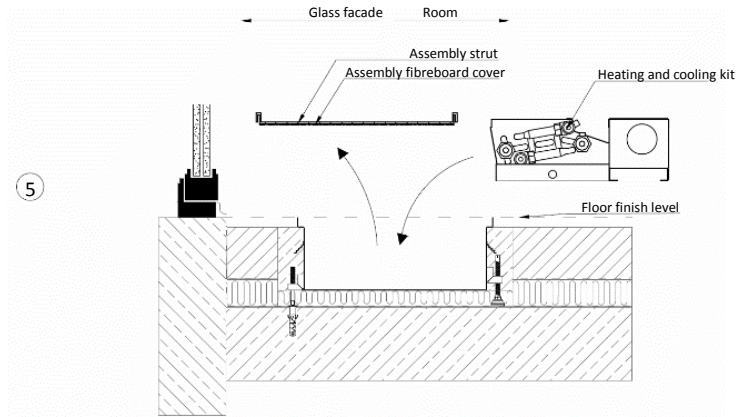

5. Install the heating and cooling kit

When the concrete gets dry, remove the assembly fibreboard cover and struts. After that, clean the inside of the casing and install the heating and cooling kit.

In climaconvector type CVK4 the heat exchanger should be on the glass facade / wall side.

If the regulating valves are factory installed, then:

- check and correct the condition of heat exchanger connections with valves of central heating system,
- unscrew the valves of cooling system and make an insulated connection with the heat exchanger (using Teflon tape for example).

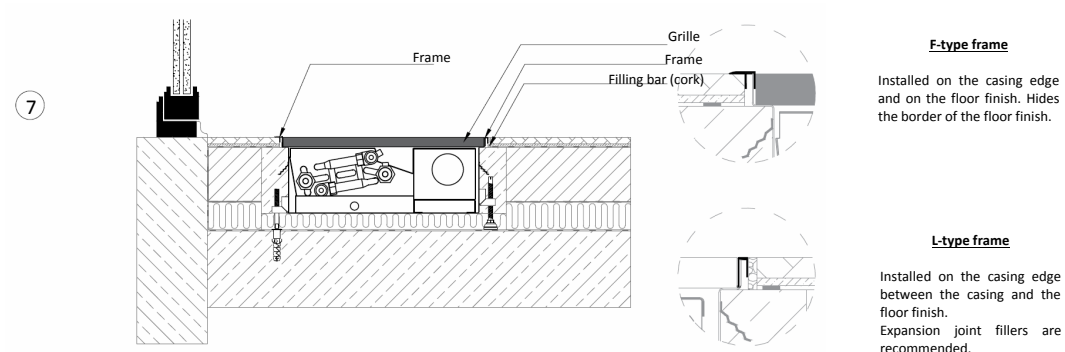

7. Install the grille and frame

After finish the rest of building works remove the assembly fibreboard cover. Then install the frame and the grille on the casing. Space between finish floor and casing / frame fill by expansion joint fillers eg. cork strips.

The climaconectors used in heating season should not be covered by carpets, furniture or curtains. Grilles can resist pressure and abrasion of low intensity pedestrian traffic. It is recommended to avoid high pressure on the grille bars caused by furnish and any other heavy elements.

Periodic climaconvector cleaning is recommended due to the influence of dust and dirt on the heat output efficiency of heater.

NOTE!

Room controllers, power supplies and assembly fibreboard covers are additional equipment accessories.

Making the pre-setting on the pressure independent control valve (PICV)

Making the correct pre-setting enables correct work of the climaconvector. Making the wrong setting or leaving the factory setting may lead to too low or too high flow through the heat exchanger, which may result in: too low power of the device, too high power of the device, lack of balancing in the heating and cooling system.

The setting should be selected as specified in the project. In the absence of this information, it should be selected for the appropriate flow according to the table below and in the valve data sheet. Check the valve type used in the climaconvector before selecting and executing the setting.

Detailed information on setting and valves are available in the technical data sheet and valve user manual.



The type designation (eg. **A90**) is located on the top side of the ring on which the actuator is installed



The setting should be made with a flat screwdriver

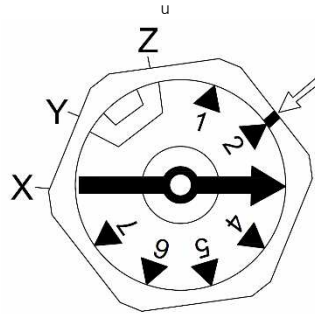

Example: setting 2 (or 2+ 360°)

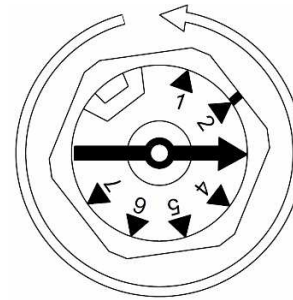

+360° corresponds to full rotation

View of the CVK2 connection chamber

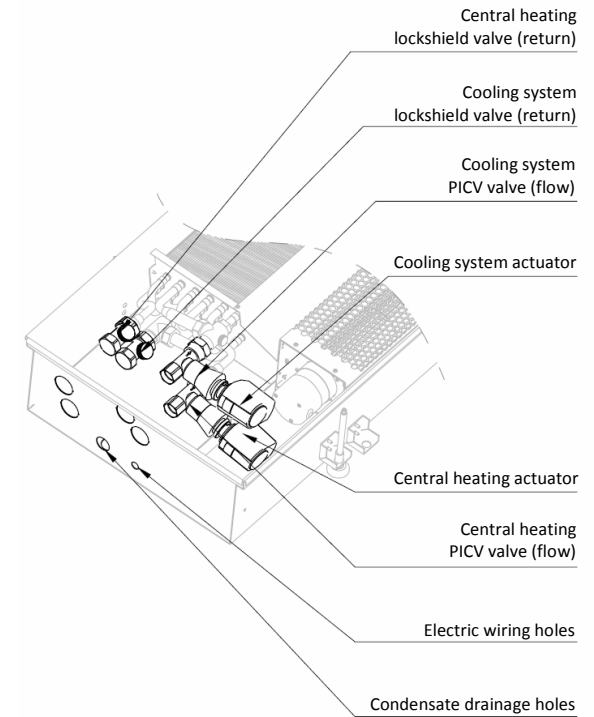

Type designation	Reference number									Reference number + 360°								
	1	2	3	4	5	6	7	X	Y	Z	1	2	3	4	5	6	7	X
	Volume flow [l/h] in relation to the valve stroke or the reference number of the pre-setting																	
A-45	25	36	45	53	60	67	72	77	81	85	88	91	93	96	98	100	102	104
A-90	57	75	90	103	114	123	132	139	145	151	156	160	165	169	173	177	181	185
A-145	86	117	145	169	189	207	223	236	248	258	267	276	284	291	298	305	311	318
B-200	95	151	200	243	280	311	339	362	383	400	415	428	439	450	459	467	475	483

CVK4 climaconvector wiring diagram – room controller VER-44 WiFi

The controlling function for climaconnectors is handled through wall-mounted control panel that service the actuators and fans. It has the room thermostat built in that is responsible for measuring room ambient temperature and by regulating the opening angle of the valves and fan revs it will keep the constant room temperature value. It also offers the optional local temperature control that is managed over the Internet (VER-44 WiFi controller dedicated only for 2-pipe CVK2 and 4-pipe CVK4). For BMS system room controller and temperature sensor is usually split into 2 separate devices.

The following are required for correct operation of climaconvector: room controller, 0-10 V thermal actuators installed on PICV valves and 24 V DC power supply unit (selected according to the electrical characteristics of installed climaconnectors) installed in the electric cupboard.

The room air controller is connected to the heater fan and the actuators (see diagram). The recommended cable type for control system is LIY or LIYCY. Due to the built-in temperature sensor the room controller should not be covered with furniture or other interior design elements.

It is also possible to connect several climaconnectors to a single controller. In order to do that the heating zones should be correctly designed – the numbers of fan motors and actuators should not exceed 50 pieces in one zone. The 24 V DC power supply should be protected by an appropriate overcurrent circuit breaker and an installation switch off that allows the power cut off while conducting service work on VERANO products. Each heating/cooling zone should be controlled by the single room temperature controller.

WARNING!

Electric wiring should be done only by the electrical skilled worker who can confirm his membership in an approved self-certification scheme. Power can only be switched back on when the correctness of the whole wiring was checked and approved. Due to use of safe low-voltage fans the climaconnectors can only be powered by 24 V DC voltage. It is prohibited to connect the climaconnectors directly to 110 V AC / 230 V AC power grid.

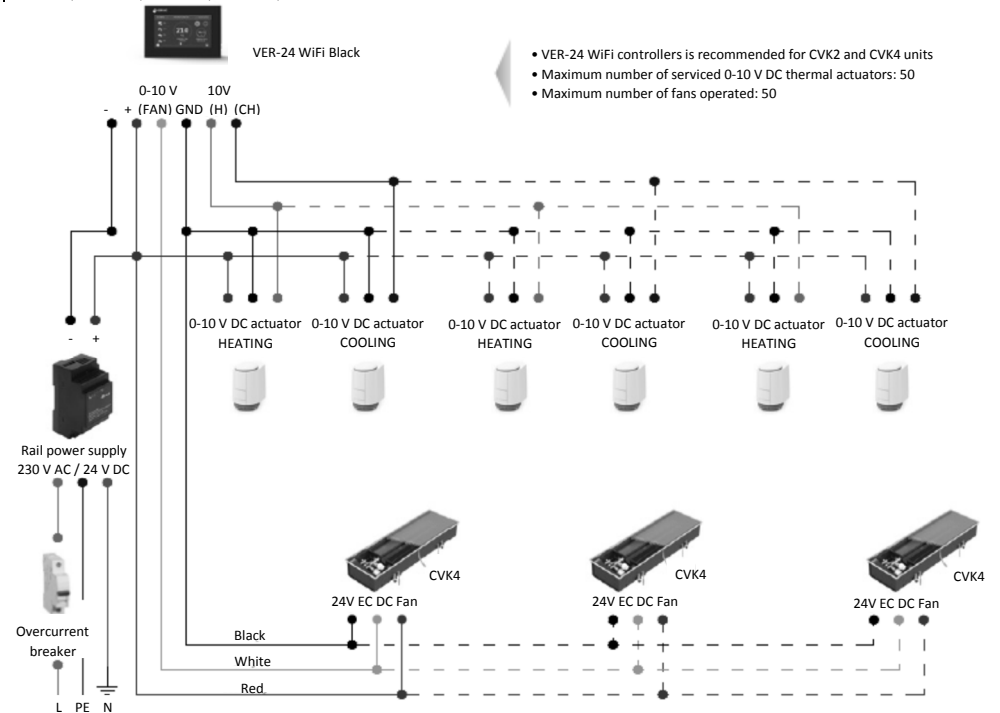

- VER-24 WiFi controllers is recommended for CVK2 and CVK4 units
- Maximum number of serviced 0-10 V DC thermal actuators: 50
- Maximum number of fans operated: 50