

Instalation Manual
Of Fan assisted VKN
TRENCH HEATER

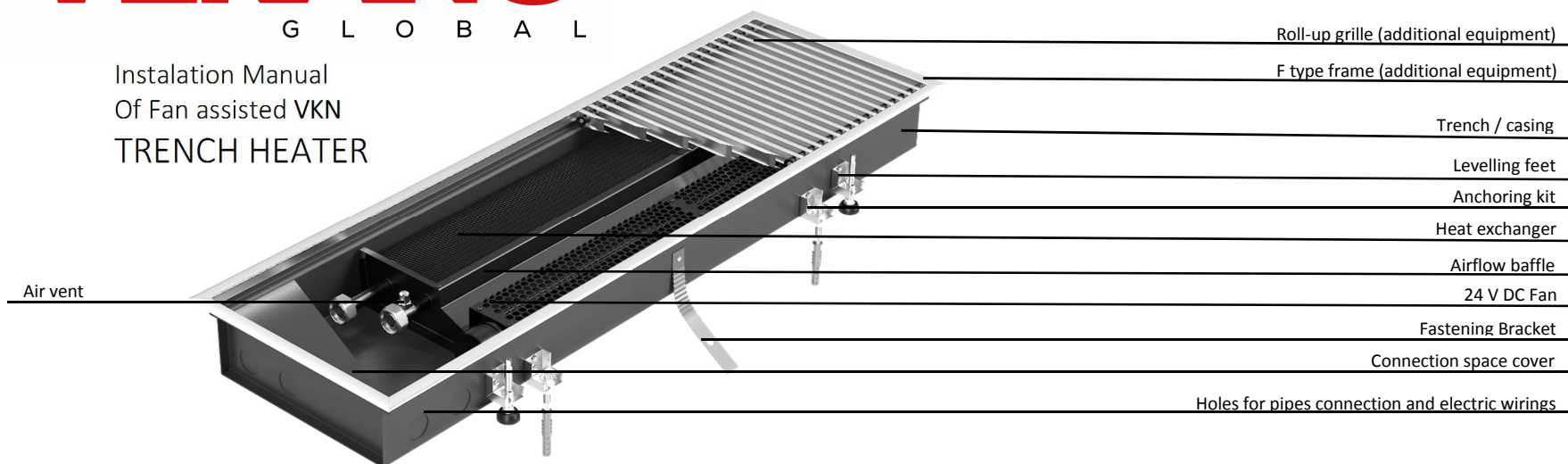

Electric connection



Fan electric connection:

- Red – positive (+) 24 V DC
- Black – negative (-) 24 V DC
- White – control voltage 0-10 V DC

Recommended wire type: LIYCY

Allowed wire type : LIY

Electrical wires routing should be done in accordance with the applicable standards of the electrical industry.

The cable cross-section should be determined in accordance with electrical installation project based on the voltage drop calculations for the planned wires routing.

Frame type and heater height

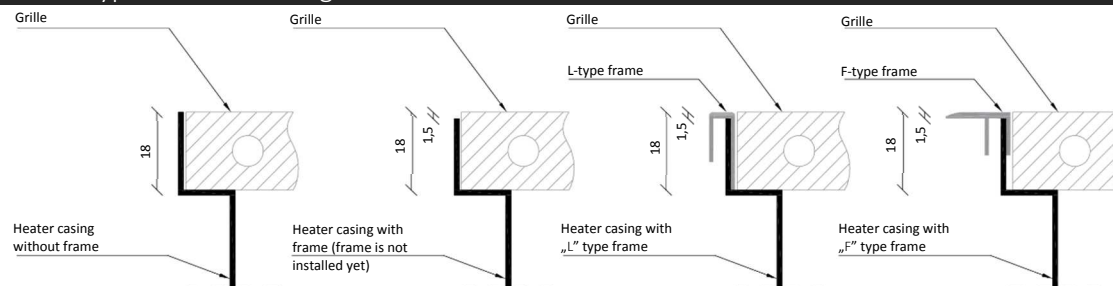

The height of the casing edge depends of the frame type. It is recommended to order frame together with heater or inform manufacturer about planned frame installation on later stage.

Casing edge for heater without frame is 18 mm high – the same as the grille. Casing edge for heater with frame is 16,5 mm high. Thanks to that, after installing the 1,5 mm frame, grille and frame are on the same level.

„F” frame should be installed on the casing after completing all installation and building works, according to the point ⑦ of this manual.

If you have any questions or doubts concerning installation works, please contact us:

VERANO OFFICE
Tel. +44 20 3290 0665
e-mail: export@v-k.pl
www.verano-global.com

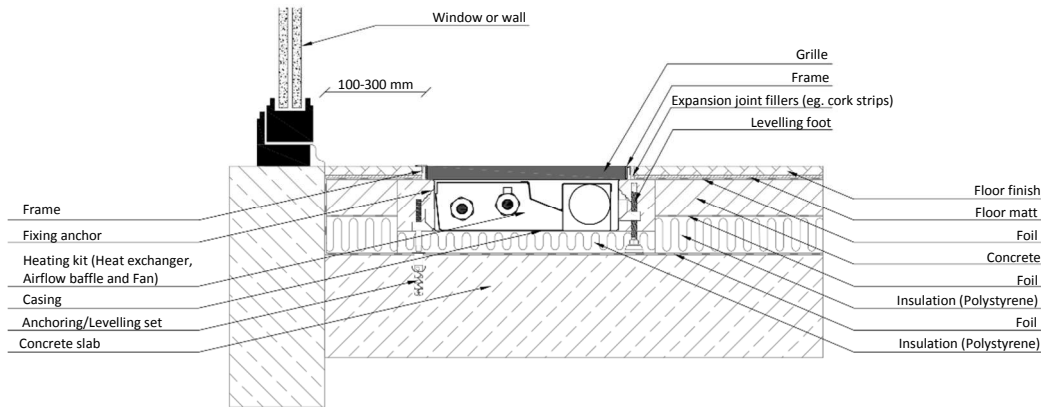

The example of VKN fan assisted heater assembly

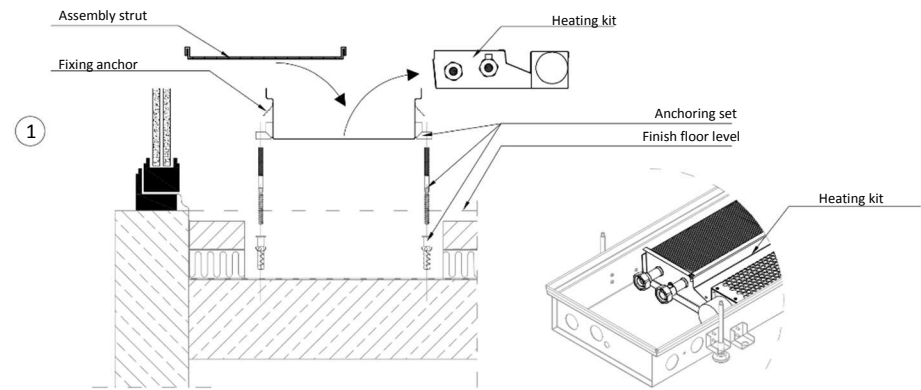

1. Prepare a duct for the heater

Before starting the assembly works take out and secure the heating kit (fan, airflow baffle and heat exchanger). After that, install assembly struts on the casing.

Prepare a duct 100 mm wider and longer than heater casing. For easy installation the depth of the trench should be planned in the way that the top of the grille is on the same level as floor finish level (take into account insulation in the bottom of the trench).

Put the heater casing in the centre of the duct. Point the places for fixing anchors holes on the concrete. Put out the heater casing of the trench.

NOTE!

Fans contaminated by dirt and dust while building or renovation works might cause damage of fans or louder fan work. Damage caused by fan contaminations are not covered by the warranty.

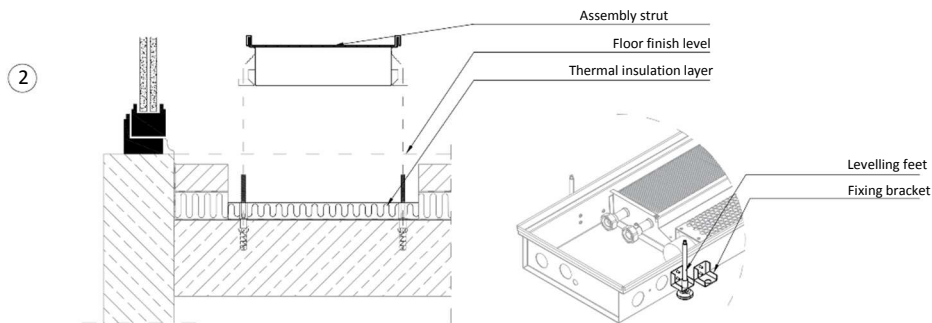

2. Heater fixing and thermal insulation

Prepare an appropriate holes for anchoring screws in concrete slab. Drill the holes on marked points and hammer the raw plugs into them.

Place the thermal insulation on the concrete slab below trench casing. Remember to do the holes for fixing anchors and levelling feet in insulation. The recommended thermal insulation is Polystyrene.

The thermal insulation layer under the casing should be done of materials of relative deformation factor not less than 70 kPa while compressive strength is at 10%.

The minimum insulation thickness should be not less than:

- 20 mm for heaters installed in an upper levels (above the floor with central heating system),
- 140 mm for heaters installed on the ground floor (Polystyrene declared properties $\lambda = 0,004 \text{ W/m}^*\text{K}$, $U_{min} = 0,30 \text{ W/m}^2\text{K}$).

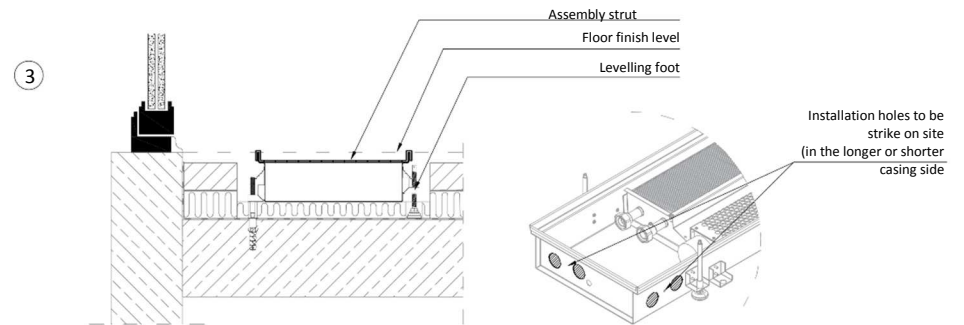

3. Install the heater casing in the duct

Strike the holes for connection pipes and for electric wires. You should strike 3 holes in one side of the casing (longer or shorter side).

Put the casing with levelling feet in the duct. Levelling feet should be placed on the concrete slab. Do not install levelling feet on thermal insulation. Use the screwdriver to level the unit by levelling feet.

Screw the heater casing using fixing anchors kits. Screw the M8 nut on the fixing anchor until resistance is felt.

Fill the rest of the free areas between the heater casing and thermal insulation with low expandable foam.

Leaving free space between the casing and thermal insulation can lead to increased volume of device.

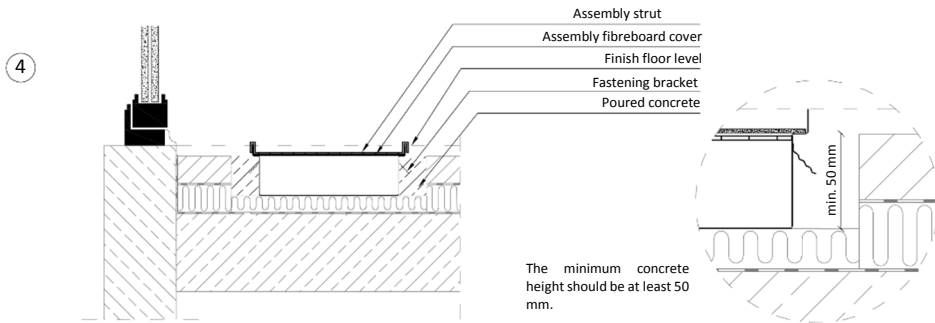

4. Do the hydronic and electric connections, pour the concrete around the casing

Install all pipes and electric wires. Secure the connections and all the holes in the casing by using low expandable thermal foam insulation. Make sure that the casing is properly settled in the trench and all connections are done. Make sure that assembly struts are installed on the top edge. One pouring the concrete put assembly fibreboard cover on the casing to avoid contamination inside the casing. Pour the concrete around the casing. The minimum height of concrete should be at least 50 mm.



Tray of fan assisted trench heaters VKN are standardly equipped with a connection for connecting the grounding installation. To be used depending on local or special guidelines (the requirement to use PELV circuits for example). According to the current regulations, low voltage devices (fan assisted trench heaters VKN) should not be connected to the grounding of other installations.

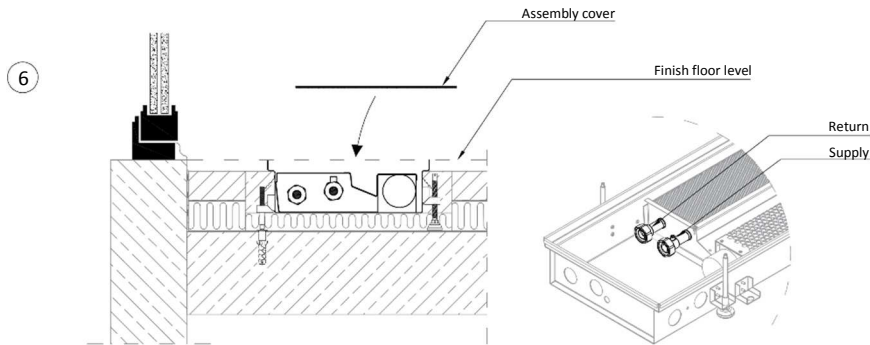

6. Do the hydronic and electric connections to the heating kit

Install valves and thermal actuators (if required) on the pipes of heat exchanger. Connect the pipes to the valves. Supply pipe is to be connected to the heat exchanger pipe with air vent (on the room side). Connect electric wires to the fan. Use the electric scheme to do the wiring for the thermal actuator and the controls.

Carry in the tightness test for hydronic connections.

After completing installation works, cover the heater with the assembly fibreboard cover to avoid contamination of fan and heat exchanger with dust of the rest of building works. Damage caused by the heating kit contamination is not under warranty.

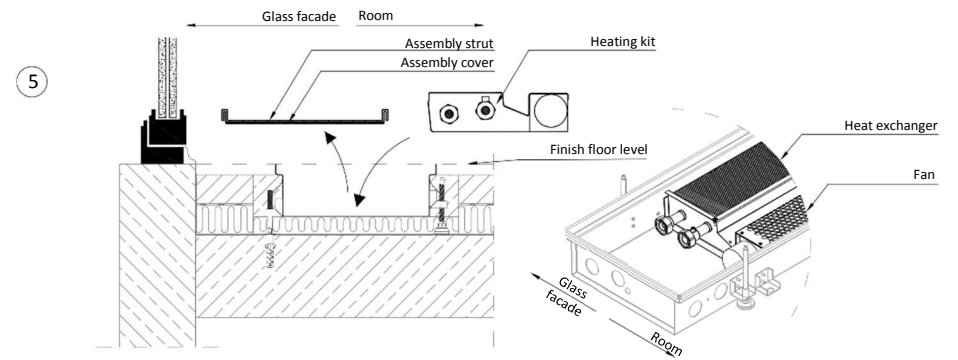

5. Install the heating kit

When the concrete gets dry, remove the assembly fibreboard cover and struts. After that, clean the inside of the casing and install the heating kit.

In fan assisted trench heater type VKN the heat exchanger should be on the glass façade / wall side.

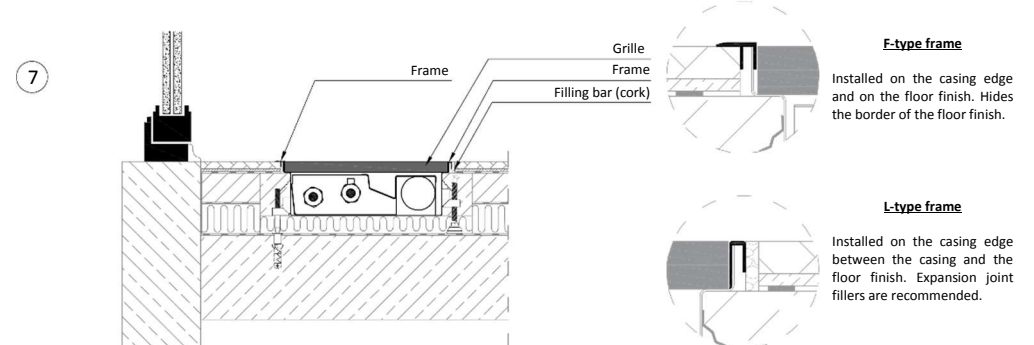

7. Install the grille and frame

After finishing the rest of building works remove the assembly fibreboard cover. Then install the frame and the grille on the casing edge. Space between finish floor and casing / frame fill by expansion joint fillers eg. cork strips.

The trench heaters used in heating season should not be covered by carpets, furniture or curtains. Grilles can resist pressure and abrasion of low intensity pedestrian traffic. It is recommended to avoid high pressure on the grille bars caused by furnish and any other heavy elements.

Periodic heater cleaning is recommended due to the influence of dust and dirt on the heat output efficiency of heater.

Note!

Grilles, frames, thermostatic and lockshield valves, thermal actuators, rail power supplies and protective fibreboard are additional equipment accessories.

VKN heater wiring diagram

Fan assisted trench heaters are controlled automatically by room air controller and thermal actuators. The built-in thermal sensor controller measure the room air temperature and keeps it at a settled level. The high precision of that adjustment is the result of the simultaneous, fully automated control of both the 2-position actuator and the fan motor.

The following are required for correct operation of trench heater with fan: room controller, thermal actuator installed on thermostatic valve and 24V DC power supply unit selected according to the electrical characteristics of installed heaters.

The room air controller (see diagram below) is connected to the heater fan and the actuator installed on the thermostatic valve. The recommended cable type for control system is LIY or LIYCY. Due to the built-in temperature sensor the room controller should not be covered with furniture or other interior design elements.

It is also possible to connect several fan-assisted heaters to a single controller. In order to do that the heating zones should be correctly designated. Number of fan motors should not exceed 12 pieces in one zone. The detailed electric data are presented in the respective sections of the product catalogue.

Verano also offers 230V AC/ 24V DC DIN-rail power supply units. The power supply unit should be protected with appropriate overcurrent protection that will also allow to switch the power off during service and maintenance.

DIN power supply units should be installed in electric cupboard outside the casing.

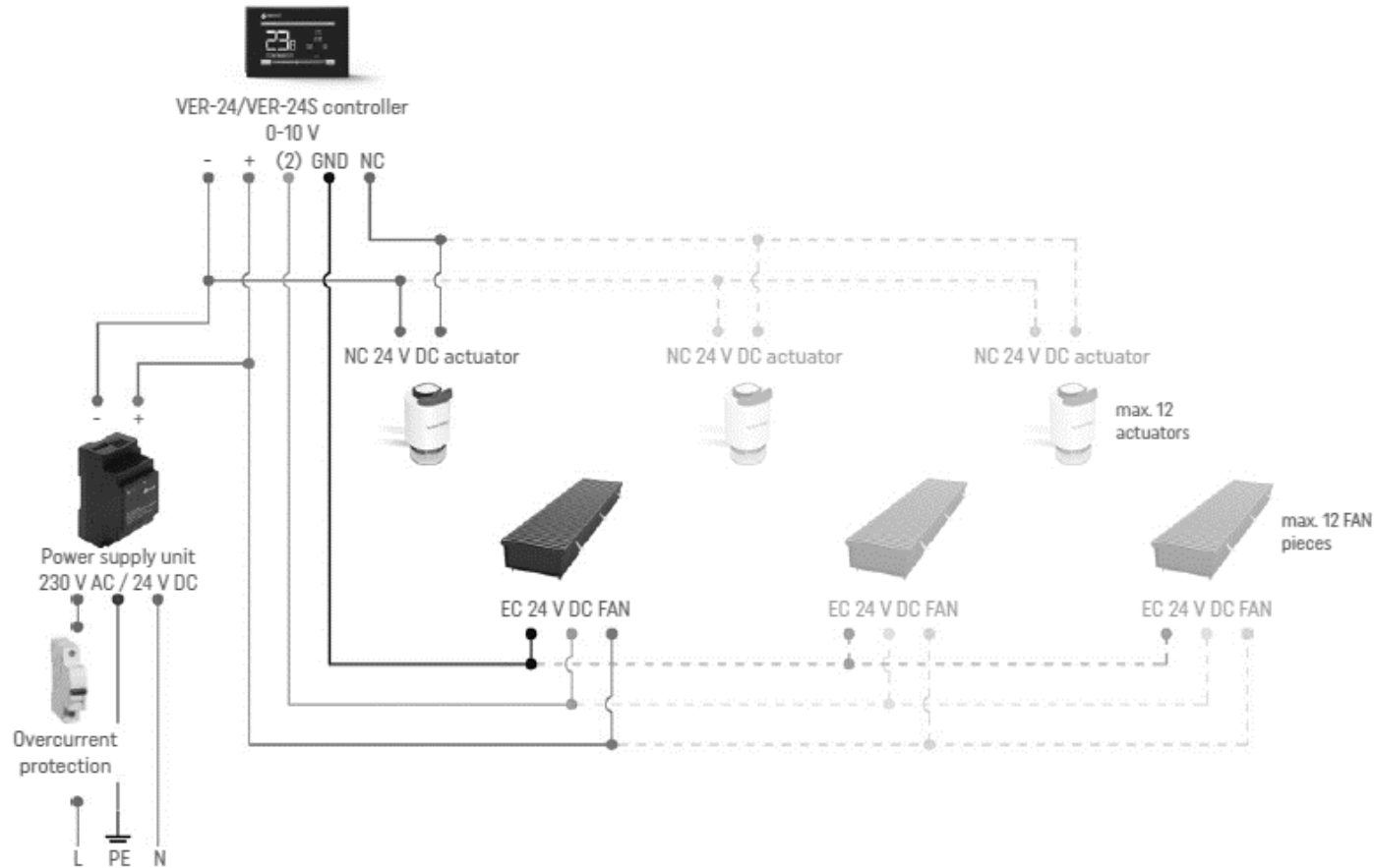

WARNING!

Electric wiring should be done only by the electrical skilled worker who can confirm his membership in an approved self-certification scheme. Power can only be switched back on when the correctness of the whole wiring was checked and approved.

Due to use of safe low-voltage fans the heaters can only be powered by 24V DC voltage. It is prohibited to connect the heaters directly to 120V / 230V power grid.