



**Air handling unit with heat recovery
freshAIR+ VST / VSH/ VSE**

Installer manual



The manual should be kept close to the device.

Table of contents

1. Introduction.....	5
1.1. General information.....	5
1.2. Nameplate.....	5
1.3. Symbols.....	5
2. Safety6	
2.1. Responsibility.....	6
2.2. Protection of the environment and disposal	6
2.3. Safety rules.....	6
2.4. Safe use.....	6
3. Product information	7
3.1. Device description	7
3.2. Product overview	8
3.3. Product dimensions	9
3.4. Technical data and available variants of the device	9
3.5. Transport and storage	10
3.6. Working conditions	10
3.7. The scope of basic supplies	10
3.8. Available accessories:	10
4. Components used in AHUs.....	11
4.1. Heat exchanger.....	11
4.2. Automatic Bypass	11
4.3. EC fans with Constant Flow	11
4.4. Air filters	11
4.5. PTC pre-heater	11
4.6. Casing made of expanded polypropylene	12
4.7. Condensate drain	12
4.8. Built-in water reheater	12
4.9. AHU controller	12
5. Operating the controller.....	12
5.1. User menu – structure.....	12
5.2. The controller control.....	13
Panel ecoTOUCH T4_RT:.....	13
Panel simTOUCH2:.....	14
5.3. Switching controller on and off	14
Panel ecoTOUCH T4_RT:.....	14
Panel simTOUCH2:.....	14
5.4. Main screens.....	15
Panel ecoTOUCH T4_RT:.....	15
5.5. Description of the controller's operation	17
5.5.1. Controller operation modes	17
5.5.2. Device operation modes.....	17
5.5.3. Settings of operating states	18
5.5.4. User modes	18
5.5.5. Balanced ventilation function.....	18
5.5.6. GHE support	18
5.5.7. Bypass support.....	19

5.5.8. Burglar alarm system.....	19
5.5.9. Schedules.....	19
5.5.10. Filters replacement procedure.....	20
5.5.11. Exchanger cleaning.....	20
5.5.12. General settings.....	20
5.5.13. Cooperation with differential pressure sensors.....	21
5.5.14. Internet module cooperation.....	21
5.5.15. Alarms and prompts	24
5.5.16. Cooperation with air parameters sensors.....	26
6. Installation and service settings.....	27
6.1. General Information.....	27
6.2. Place of installation	27
6.3. Installation of the device	27
6.3.1. Minimum distances and service space	27
6.3.2. Wall mounting	27
6.3.3. Installation on the floor of the room	28
6.4. Connecting the condensate drain	29
6.5. Connecting the air handling unit to ventilation ducts	29
6.6. Connecting the electric installation and control system	30
6.7. Connecting the electric installation and control system	31
6.7.1. Central control according to demand	31
6.7.2. Central control according to demand	33
6.7.3. Local control according to demand (DCV).....	34
7. Commissioning and acceptance of the installation.....	35
7.1. Before commissioning the installation	35
7.2. The first run	35
8. Service and maintenance works	35
8.1. Filter replacement	35
8.2. Removing the service cover	35
8.3. Heat exchanger service	37
8.4. Bypass service	37
8.5. Fan service	37
8.6. PTC pre-heater service	38
8.7. Service of the air cleaning module with a UV lamp	39
8.8. Condensate drain service and control	39
8.9. Service and maintenance of the controller	40
9. Operation of the controller for the installer	40
9.1. Technical data.....	41
9.2. Operating conditions	41
9.3. The controller installation	41
9.4. Mounting of control panel.....	41
9.5. Main module installation.....	43
9.6. Cleaning and maintenance procedures.....	43
9.7. Electrical connection.....	43
9.8. Electrical diagram	44
9.9. Temperature sensor connection and installation	45
9.10. Temperature sensors testing	45

9.11. Connecting differential pressure sensors.....	45
9.12. Connecting differential pressure sensors	46
9.13. Connecting air parameters threshold sensor.....	46
9.14. Connecting the internet module.....	46
9.15. Air filters.....	46
9.16. Modbus communication.....	46
9.16.1. Modbus RTU protocol.....	46
9.16.2. Communication settings.....	46
9.16.3. Read request 0x03.....	47
9.16.4. Modification request 0x06.....	47
9.16.5. Modification request 0x10.....	47
9.16.6. Modbus table	48
9.17. Installer menu - structure.....	53
9.18. Manufacturer menu - structure.....	54
9.18.1. Menu - Unlock the device.....	56
9.19. Description of the installer parameters.....	57
9.20. Outputs configuration and confirmation of configuration.....	59
9.20.1. Heaters.....	60
9.20.2. Cooler.....	60
9.20.3. GHE.....	60
9.20.4. By-pass.....	60
9.20.5. Rotary exchanger.....	61
9.20.6. Mixing chamber.....	61
9.20.7. CO2 and humidity threshold sensors.....	61
9.20.8. Analog CO2 and humidity sensors.....	61
9.20.9. Signal from external central system.....	61
9.20.10. Hood mode	61
9.20.11. Fans operation confirmation.....	62
9.20.12. Fire prevention system alarm.....	62
9.20.13. Filters dirtying control	62
9.20.14. Fans control modes.....	62
9.20.15. Configuration confirmation.....	62
9.21. Software update.....	62
9.22. Other functions.....	63
9.22.1. Unlocking the device.....	63
9.22.2. Power supply outage.....	63
9.22.3. Parts or components replacement.....	63
9.22.4. Mains fuse replacement.....	63
9.22.5. Control panel replacement.....	63
9.22.6. Executive module replacement.....	63
9.23. Controller dimensions	64
10. Declarations and documents	65
10.1. Energy labels of devices according to Ecodesign (1253 (1254) / 2014)	65

1. Introduction

We would like to thank you for your trust and for purchasing the Air handling unit with heat recovery produced by VERANO. For years, we have been making every effort to ensure that, thanks to high durability and quality, our products meet all your expectations.

1.1. General information

Air handling unit with heat recovery, further referred to as a recuperator, is an integral part of the mechanical ventilation system of a building or a residential and commercial premises. An installation equipped with a VERANO recuperator should be operated 24 hours a day without interruption.

This manual is a source of information for the installer and user, so please read it carefully before starting the installation and first start-up of the device. During installation and maintenance work, as well as during operation of the device, observe the recommendations contained in this manual.

In any correspondence with the manufacturer or distributor, please provide the type, order number and date shown on the nameplate of the device.

VS series recuperators have been designed for use in attics or in technical rooms of single-family and multi-family buildings. The casing made of extruded polypropylene (EPP) with a thickness of 40 mm ensures optimal thermal and acoustic insulation. Recuperators are equipped with a two-stage filtration system, a PTC preheater, a temperature, hybrid or enthalpy heat exchanger and an optional secondary heater or cooler. The applied constant flow system facilitates the adjustment of the installation and guarantees a constant air flow, regardless of weather conditions or the degree of filter contamination, and is a standard equipment of the freshAIR+ series air handling units.

Together with the recuperator, they receive a controller panel that clearly provides access to all available functions and settings. It enables remote control of the control panel operation using a web application available in a web browser or an application for tablets and smartphones available for Android and iOS systems.

The product was created as part of the research project "New generation recuperators - development of a group of innovative products" under the Intelligent Development Operational Program 2014-2020, Measure 1.1. - Submeasure 1.1.1. financed by the National Center for Research and Development.

1.2. Nameplate

The recuperator nameplate is located on the upper part of the controller casing.

1.3. Symbols

The following symbols are used in the manual:



Beware of the danger



The symbol indicates useful information and tips.



Air handling unit

freshAIR+ VWT 450 L+

VERANO GLOBAL Sp. z o. o.
ul. Vetterów 7a, 20-277 Lublin
tel.: +48 81 44-08-330
Order no. : **number**
Serial no. : **number**
serwis.rekuperatory@v-k.pl
www.veranoconvector.co.uk



Year of production:	2020
Rated voltage:	230 V AC
Rated voltage:	~50 Hz
Overcurrent breaker:	16 A
Max. power consumption with the anti-freeze system:	1850 W
Protection:	IP 40
Insulation class:	I
Max. available static pressure:	400 Pa
Max. air stream:	450 m ³ /h
Nominal air stream:	315 m ³ /h
Pre-filter:	ePM10 (75%)
Fine filter:	EPM1 (55%)

2. Safety

2.1. Responsibility

VS series recuperators are designed and manufactured for use in balanced supply and exhaust ventilation systems. Using the devices for other purposes is considered as use contrary to the intended use. The appliance must not be connected to cooker hoods.

The manufacturer is not responsible for damage to the recuperator or injuries caused by using it contrary to its intended use.

The air handling unit is intended solely for indoor operation. The required value of the ambient temperature of the device is in the range from + 5 ° C to + 40 ° C, relative humidity up to 70%.

2.2. Protection of the environment and disposal

The high quality of products as well as the economy and ecology of production, operation and disposal are for Verano Global Sp. z o. o. equal goals. We strictly adhere to environmental standards and regulations.

Taking care of the environment, we optimize production methods by reducing the amount of waste and using materials that can be completely recycled.

Factory packaging:

The packaging used for storage and delivery is suitable for later use. The packaging, along with the purchased device, becomes the property of the user. therefore, disposal is the responsibility of the user or installer who is responsible for delivering and installing the product.

Waste equipment:

After the service life of the product has expired, it should not be disposed of with other municipal waste.

Pursuant to the regulations in force, improper disposal may lead to the imposition of administrative penalties.

Out of concern for the natural environment, please recycle the device responsibly at the end of its life. The device components contain materials that must be sorted and recycled or disposed of. Component access methods are described in this manual.

Take materials and components such as compressors, fans, circulation pumps and printed circuit boards to a waste disposal facility or dealer that provides disposal services.

2.3. Safety rules

Before starting any works related to the assembly or operation of the recuperator, please read this manual. For the safety and comfort of users, installation, assembly and service works should be carried out by a qualified installer in accordance with applicable regulations, accepted principles of engineering practice and this manual.

The devices are intended for use in single-family houses, single apartments and buildings of similar purpose. Alternative applications of the device should be consulted with the manufacturer before purchase.

The manufacturer is not liable for any damage resulting from failure to comply with safety requirements and recommendations or unauthorized modification of the device without the consent of the manufacturer.

2.4. Safe use

Electrical connections, maintenance and servicing of the device should be performed only by qualified installers in accordance with the manufacturer's instructions and the applicable safety rules. Before starting any service works, make sure that the heating elements have cooled down and that the device has been disconnected from the power supply and secured against accidental start-up.

Due to the possibility of sharp and cutting edges, during maintenance and service work be careful and use protective work clothing and protection required by the provisions of Occupational Health and Safety.

It is forbidden to:

- connecting the device to a power supply other than that indicated on the label,
- operation of an unearthed device,
- powering the device with an extension cord or a power distributor,
- powering the device by an electrical installation not prepared in accordance with this manual,
- starting the device before the end of the assembly work,
- use of the device or installation connected with the device in an aggressive or potentially explosive environment,
- modify the device without the prior consent of the manufacturer,
- operation of the device by people who have not been trained or read the manual, including children,
- using the device for drying the construction site,
- wkładania ciał obcych, w tym części ciała, przez króćce przyłączeniowe do wnętrza urządzenia,
- inserting foreign objects, including body parts, through the connection stubs into the interior of the device.

The operation of the device should be stopped when:

- there will be damage to the casing, including connection nozzles,
- there is any visible or audible damage to the device,
- fluid appears on the electrical parts or connectors,
- a foreign body gets into the installation.

Before removing the foreign body, as in the case of service work, make sure that the heating elements have cooled down and that the device has been disconnected from the power supply and secured against accidental start-up. In the event of damage, immediately shut down the installation and call the service in order to replace the damaged elements.

ATTENTION! The device should be started only after connecting the ventilation ducts. Starting the device without connecting the channels creates a risk of injury from moving parts.

3. Product information

3.1. Device description

The standard equipment of the freshAIR + VS series air handling unit with heat recovery includes the following elements:

- the casing made of foamed polypropylene provides excellent thermal and acoustic insulation of the device, additionally reinforced with a structure made of powder-coated steel sheet. The casing is 100% recyclable.
- counter-current heat exchanger allowing for the recovery of sensible heat (temperature exchanger) or total heat (enthalpy and hybrid heat exchangers),
- fans with EC motors with high efficiency and low energy consumption, with the possibility of smooth adjustment of the flow.
- built-in Constant Flow function, which ensures a constant amount of air flow, regardless of the degree of dirtiness of the filters or other temporary resistance disturbing the operation of the installation. The equalization of the supply and exhaust air streams ensures the highest efficiency of heat recovery.
- PTC pre-heater, which is characterized by a stable, modular structure, low flow resistance and uniform heating of the air stream. The temperature sensor allows to reduce energy consumption and protects against overheating of the air handling unit.
- built-in automatic bypass, which in the summer period allows the intake air flow to bypass the heat recovery system, thanks

to which the temperature in the building will be reduced without the use of air conditioning.

- two-stage filtration system of the supply air: the ePM10 pre-filter (60%) allows for the sifting of coarse-grained dust floating in the air, and the ePM1 fine filter (55%) filters the tiniest dust with a diameter smaller than 1 µm: viruses, bacteria, nanoparticles and soot.
- UV lamps for air disinfection
- plugs in the casing for quick inspection and replacement of filters
- controller with a control panel that provides access to all functions and settings of recuperators, which additionally enables remote control via a web application, available in a web browser or an application for Android and iOS.

Depending on the model, the heat recovery unit can be equipped with:

- reheater or cooler with condensate pump.
- the secondary heater can be powered by the central heating system medium and installation of chilled water is required to supply the cooler
- a relative humidity sensor
- a relative humidity sensor and a wall-mounted sensor for carbon dioxide concentration or air quality

3.2. Product overview

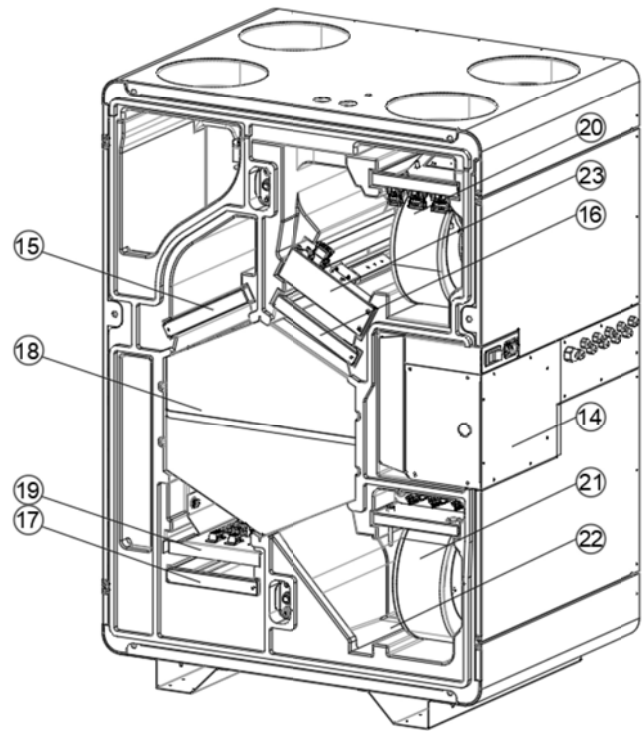
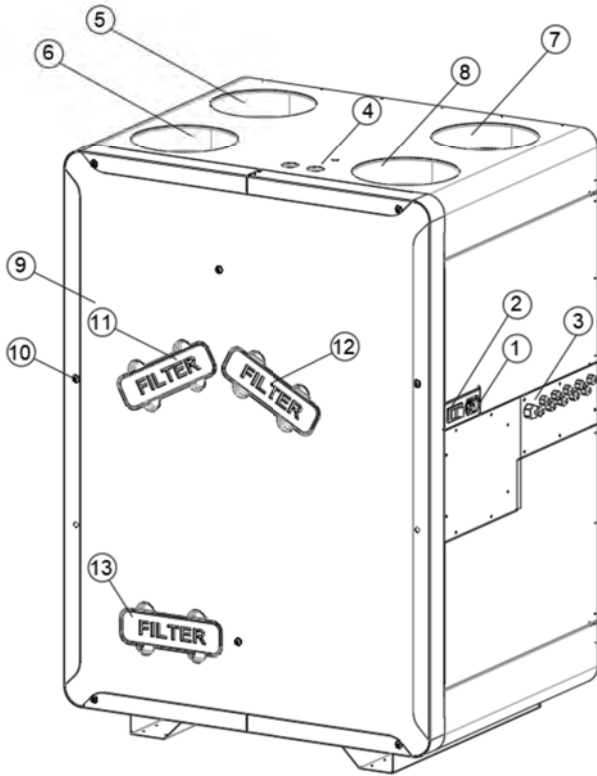

- [1] Power cord socket
- [2] Device switch
- [3] Cable glands for external equipment and AHU controller
- [4] Space for heater installation cables (option)
- [5] Connection of the exhaust air from the rooms d=180 mm
- [6] Fresh air connection from the intake d=180 mm
- [7] Connection of the air directed to the ejector d=180 mm
- [8] Connection of supply air to rooms d=180 mm
- [9] Service cover
- [10] M8 screws (x4) securing the service cover
- [11] Exhaust air filter plug
- [12] Supply air fine filter plug
- [13] Supply air pre-filter plug
- [14] AHU controller housing
- [15] Exhaust air filter
- [16] Supply air fine filter
- [17] Supply air pre-filter
- [18] Heat exchanger and bypass
- [19] PTC pre-heater
- [20] Supply air fan module with a set of connectors
- [21] Extract air fan module with a set of connectors
- [22] Drip tray and condensate drain

3.3. Product dimensions

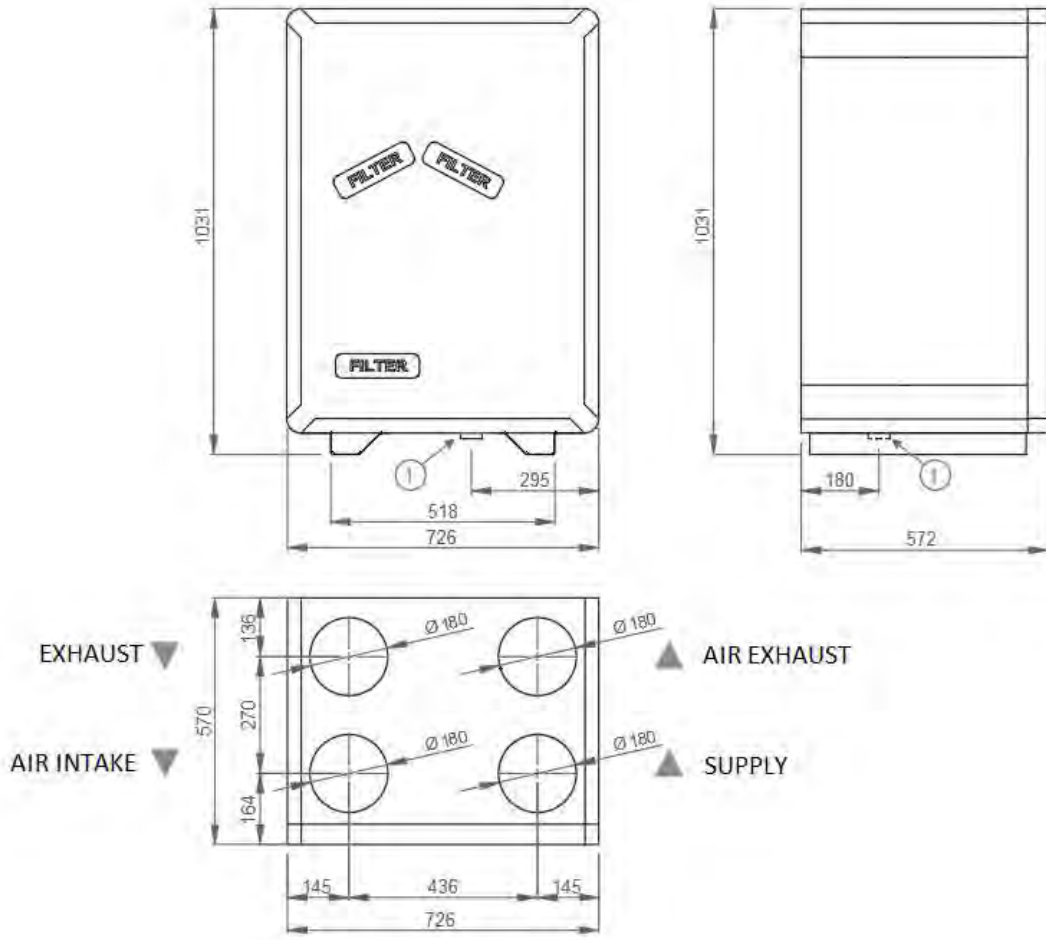

3.4. Technical data and available variants of the device

The table below lists the models of VS series heat recovery units depending on the equipment version:

Secondary, Water Heat Exchanger	Exchanger and connection side		
	Temperature	Enthalpy	Hybrid
Central control according to demand, monochrome display			
Shortage	VST 400	VSE 250	VSH 400
Heater	VST 400 H	VSE 250 H	VSH 400 H
Central control according to demand, color display			
Shortage	VST 400 +	VSE 250 +	VSH 400 +
Heater	VST 400 H+	VSE 250 H+	VSH 400 H+
Local control according to demand (DCV)			
Shortage	VST 400 DCV	VSE 250 DCV	VSH 400 DCV
Heater	VST 400 H DCV	VSE 250 H DCV	VSH 400 H DCV

FreshAIR + air handling units are available with a temperature, enthalpy and hybrid exchanger. The enthalpy and hybrid exchanger allows for the recovery of moisture from the removed air stream, protecting users against dry air in the winter.

Parameter	freshAIR+ VST 400	freshAIR+ VSE 250	freshAIR+ VSH 400	Unit
Exchanger type	TEMPERATURE	ENTHALPY	HYBRID	
Air stream				
maximum	400	250	400	[m ³ /h]
nominal	280	175	280	[m ³ /h]
minimum	90	90	90	[m ³ /h]
External pressure (for the nominal air stream)	150	250	200	[Pa]
Temperature efficiency of heat recovery				
for the nominal air stream	88	80	85	[%]
for the minimum air stream	93	86	92	[%]
Energy class				
Central control according to demand	A	A	A	
Local control according	A	A	A	
Power consumption				
for the maximum air stream at the external pressure of 100 Pa	271	81	253	[W]
for the nominal air stream at the external pressure of 50 Pa	122	52	115	[W]
Maximum sound power level (LWA)	52	49	52	[dB(A)]
Built-in PTC electric heater		1,5		[kW]
Rated voltage		230		[V]
Width		726		[mm]
Height		1031		[mm]
Depth		572		[mm]
Diameter of connection nozzles		180		[mm]
Condensate nozzle diameter		GZ 1 ¼"		[mm]
Filter class		ePM10 (60%), ePM1 (55%)		
Filters dimensions	ePM10 (60%) – 175x480x18 mm, ePM1 (55%) – 175x480x18 mm			

3.5. Transport and storage

In order to avoid transport damage, the VS recuperator is delivered on a factory pallet in a cardboard box, which protects the device. The recuperator should be transported by a forklift or other transport device. During transport, avoid shocks and impacts that may damage the device.

The device should be stored in a dry, heated room at a temperature ranging from +5 ° C to +30 ° C and relative humidity up to 60%. The recommended maximum storage time for the air handling unit is 12 months. After delivery, the device should be inspected for possible transport and storage damage. Before starting the assembly work, check the completeness and correctness of the delivery. In the case of devices subject to long storage periods, it is recommended to check:

- operation of fan bearings,
- the condition of the insulation of electric wires,
- the condition of the device casing,
- moisture inside the device,
- the presence of foreign bodies inside the device housing.

It is forbidden to lift the device by holding the connection stubs.

3.6. Working conditions

The device should be installed in a room where it will be possible to work all year round at a temperature of +5 ° C to +40 ° C. Relative air humidity in the room must not exceed 70%.

Regardless of the method of installation, the device must be level and equipped with a condensate drain.

The ventilation ducts connected with the AHU must have their own support elements and their weight cannot be carried by the device.

3.7. The scope of basic supplies

Before starting the installation, check that the delivered device is complete and undamaged.

The standard scope of delivery includes the following items:

- VS series recuperator and
 - Filter set (2x ePM10 60% filter, 1x ePM1 55% fine filter)
 - UV lamps (2 pcs.)
- Controller touch panel
- A set of documents including:
 - user manual
 - installer manual
 - energy label
 - warranty card
 - service card
 - commissioning protocol

3.8. Available accessories:

The following items can be an optional scope of delivery:

- A set of brackets for mounting the device on a wall

- A set of brackets for mounting the device to the ceiling
- Console for mounting the device on the floor
- Nipple with a seal \varnothing 200 mm (4 pcs.)
- Filter set (3 pcs.)

4. Components used in AHUs

4.1. Heat exchanger

The heat exchanger is the central element of the air handling unit, which enables heat recovery from the exhaust air to the supply air. Classically used temperature exchangers (VST unit) allow for the recovery of sensible heat, which depends solely on the temperature difference between the balanced air streams.

Hybrid (VSH) and enthalpy exchangers (VSE), thanks to a special membrane, also allow for moisture recovery.

Hybrid and enthalpy exchangers differ in the degree of moisture recovery from the removed air.

Moisture recovery has double benefits:

- total heat recovery (including energy contained in water vapor),
- humidification of air supplied to rooms in winter.

Blowing dry air into the rooms reduces comfort (coughing, feeling dry in the throat, irritation of the eyes) and causes dust to rise in the rooms.

4.2. Automatic Bypass

The bypass is an additional duct built into the recuperator, which allows the intake air stream to bypass the heat recovery system. In the transitional and winter period, the recuperator allows for the recovery of heat from the air removed from the rooms. In summer, when the outdoor air temperature in the evening and night hours is lower than that of indoor air, the heat recovery system may be bypassed. As a result, the air temperature in the building will be lowered without the use of air conditioning.

The bypass operation in VS units is regulated automatically, unless the User selects the option of manual control of the bypass flap. A detailed description is included in the controller manual

4.3. EC fans with Constant Flow

The fans used in the VS series AHUs are characterized by a built-in Constant Flow function, thanks to which the flow set by the user is maintained despite changes in pressure resistance in the installation caused by e.g. contamination of the air filters. Adjusting the air stream is based on the expected value - there is no need to determine the operating point based on the calculations for the ventilation system made.

Fans with EC motors have been matched to the air streams present in each of the recuperators, thanks to which their operating point is in the area of high efficiency. Combining them with a dedicated controller and various available sensors allowed to achieve the energy efficiency class for individual models at level A.

The used fans with EC motors are characterized by high efficiency and low energy consumption in the entire operating range. The modern, compact design allows to limit heat generation, reduce engine vibrations and extend the life of the device. The 0-10 V control signal enables smooth regulation of the fans.

- UV lamps (2 pcs.)
- Washbasin siphon with aeration
- Damper actuator with spring return
- Heating cable with a thermostat to heat the condensate drain

The equalization of the supply and exhaust air streams ensures the highest efficiency of heat recovery.

AHU flow rate adjustment is described in the chapter of the controller manual.

4.4. Air filters

VS series air handling units are equipped with three filters, including a two-stage supply air filtration system. The used pre-filter ePM10 (60%) allows for the sifting of coarse-grained dust floating in the air, and the ePM1 filter (55%) sifts the finest dust with a diameter smaller than 1 μm : viruses, bacteria, nanoparticles, soot. Quick control and replacement of filters in VS series units is possible after removing the plugs in the side cover of the device. Filters used in VS series air handling units:

1. ePM10 extract air filter (60%)
2. ePM10 supply air pre-filter (60%)
3. Exhaust air fine filter

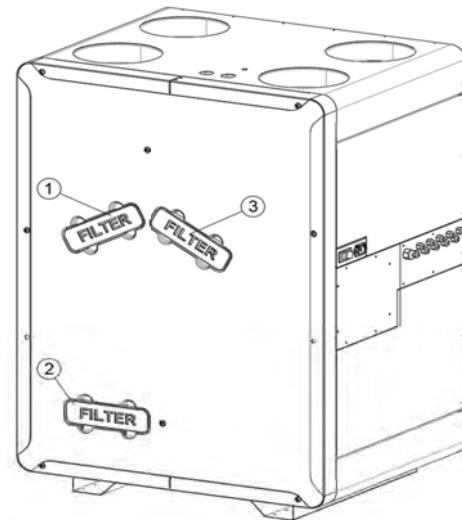

The filtration system has been developed and tested in cooperation with the Department of Indoor and Outdoor Air Quality of the University of Technology. The efficiency of air disinfection was determined at the level of min. 70% for three strains of bacteria (*Micrococcus luteus*, *Pseudomonas fluorescens*, *Bacillus subtilis*).

4.5. PTC pre-heater

Generally, when the outside air temperature drops below the freezing point, the condensate formed within the heat exchanger in the extract air chamber freezes up. The use of a preliminary heater protects the heat exchanger against freezing.

The device is equipped with a preliminary heater consisting of self-regulating PTC modules.

The pre-heater is installed after the supply air pre-filter, directly in front of the heat exchanger.

The heater has been secured with an additional temperature sensor to prevent overheating. The algorithm of the controller also allows to adjust the operation of the heater to the real heat demand, significantly reducing electricity consumption.

4.6. Casing made of expanded polypropylene

The recuperator housings are made of an injection-molded polypropylene foam, which is the structure of the individual components of the recuperator. The production process is subject to restrictive requirements and is carried out in accordance with the ISO IATF 16949 and ISO 9001 quality management system and the ISO 14001 environmental management system.

The housing material is 100% recyclable.

Matching parts, made with the use of injection molds, guarantee tightness unattainable by classic sheet metal housings, and the structure of the material ensures low weight of the device. It is also possible to make a recuperator with a casing completely covered with a steel sheet.

The use of 40 mm thick foamed polypropylene also provides excellent thermal and acoustic insulation of the device.

4.7. Condensate drain

The air handling unit has a factory-installed condensate drain with a 5/4 "thread. The drain should be connected with a siphon and a condensate drain system.

- It is recommended to use an aerated wash basin siphon

In the case of gravity installations, it is recommended to keep the line slope of at least 3%.

4.8. Built-in water reheater

As an option, the device can be factory-fitted with a water secondary heater with a copper - aluminum heat exchanger.

The heater should be connected to a central heating installation or a special technological heat installation using the set of valves with an actuator included in the set. The actuator should be connected to the AHU controller, which will ensure a comfortable air temperature for the user and protect the device from overheating.

The secondary water heater is designed to work in the water system. The heater must not be combined with direct expansion systems. The recommended factor is water treated for use in the central heating system.

In order to protect the water against freezing in winter, it is recommended to use a 30% propylene glycol-based admixture in the water system, dedicated to heating systems.

A description of the capacity, installation, service and maintenance work is described in a separate document that is included with the purchase of a secondary water heater. Built-in water air cooler

The device can optionally be factory equipped with a water cooler with a copper - aluminum heat exchanger.

The cooler should be connected to the chilled water system using the set of valves with an actuator included in the set. The actuator should be connected with the AHU controller, which will ensure the comfortable air temperature and protect against overcooling of the supplied air.

The cooler is designed to work with chilled water as a refrigerant. It is forbidden to connect the cooler with direct expansion systems.

A description of the power, installation, service and maintenance work is described in a separate document that is included with the purchase of the water cooler.



4.9. AHU controller

The controller has been designed especially for VERANO freshAIR + recuperators. It clearly provides access to all functions and settings of VS series recuperators. It enables remote control of the AHU operation using a web application available in a web browser or an application for tablets and smartphones available for Android and iOS.

The controller also allows you to save data on the operation of the unit in real time - on the server. The data is used during service inspections and allows for quick detection of irregularities in the operation of the device. The controller is available in a version with a color VER-AHR WiFi touch panel or with a VER-AHM WiFi module (control of operation only via the application).

5. Operating the controller

5.1. User menu - structure

Device operation modes	
Tryb pracy centrali	
<ul style="list-style-type: none"> • Main mode: Pause, Mode 1...4 • Time mode: OFF, Out, Party, Airing • Summer / Winter: Auto, Summer, Winter, Ventilation • Fireplace No, Yes, Speed • Schedules: No, Yes 	
Summer / Winter mode	
<ul style="list-style-type: none"> • Auto, Summer, Winter, Ventilation • Winter Mode turn on • Temperature hysteresis of Summer Mode turn on 	
Operation modes settings	
<ul style="list-style-type: none"> • User modes settings 1...4 <ul style="list-style-type: none"> – Airing, Exhaust, Comfort temp. • Time mode settings <ul style="list-style-type: none"> – Airing: Duration, Speed – Party Duration, Comfort temp., Air supply, Exhaust – Out: Duration • Schedules settings <ul style="list-style-type: none"> – Time 1...5, – Monday ... Sunday; – Start, Stop; – Mode, Reset, Copy schedules • Leading control sensor <ul style="list-style-type: none"> – Supply air sensor, Exhausted air sensor, 	
Panel sensor	
– Panel address	
Constant operation settings / User modes settings	
Mode 1, Mode 2, Mode 3, Mode 4	
Supply, Exhaust, Comfort temp.	
Filters*	
Force filters replacement procedure	
Filters replacement procedure completed?	

Filters replacement procedure

- Supply air filter – class: Standard/G4/M5, Medium/M5/M6, Fine/F7/F8
- Exhaust air filter – class: Standard/G4/M5, Medium/M5/M6, Fine/F7/F8
- Is supply air filter replaced?
- Is exhaust air filter replaced?

GHE* 

GHE settings

- Auto, Open, Close
- Summer opening temp.,
- Winter opening temp.

Regeneration settings

- Max. GHE open time
- Regeneration duration
- Manual start

Bypass/Heat recovery* 

Open, Closed, Auto*

Minimum speed, Maximum speed, Auto

Burglar alarm system 

Alarm system support

Input logical state

- NC, NO

AHU reaction

- Turn off AHU, Extract, Supply

Airing function

- Yes, No

Airing settings

- Exhaust fan speed
- Supply fan speed
- Airing duration
- Periodic airing time
- Secondary heater work during airing

Exchanger cleaning*

Cleaning start hour

General settings 

Parental control

Screen saver settings

Settings change is done using pie menu.

- On/Off screen saver
- Time till screen saver
- Screen saver backlight

Button sound

Default settings

Clock

Date

Brightness

Alarms sound

Language

Software update

ecoNET settings*

SSID

WiFi encryption type

Password

Alarms 

Service settings 

Information 

Turn on / off the controller 



Individual items of the menu may not appear if there is no suitable sensor, devices, menu settings or the controller is turned on. These positions are marked with “*” symbol.

5.2. The controller control

Panel ecoTOUCH T4_RT:

A touch screen has been used to control the device.

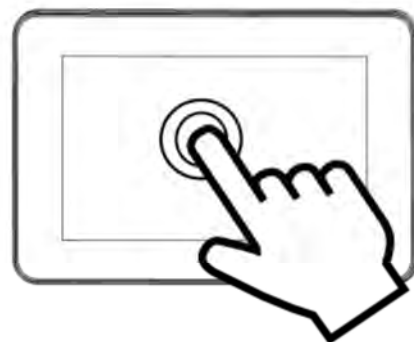

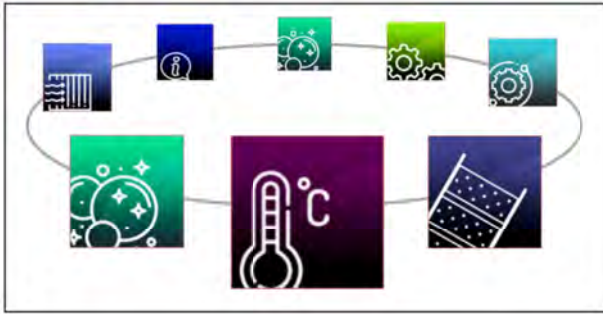

Selection and edit in the menu is done by pressing desired symbol on the screen. Grouped parameters from the selected menu are displayed on one screen. An example of such parameters grouping is shown in the figure below.



On-screen symbol meanings:

- return to the previous menu or no acceptance of parameter setting.

- fast return to the main screen from each menu level.

- information about selected parameter.

- main menu;

- decrease or increase parameter value;

- service menu;

- sliding list of parameters;

- enter selected menu option or accept selected parameter setting.

- decrease or increase value of the on-screen selected parameter.

The controller is operated using touch buttons, which allow selection of individual positions from the menu and parameters edit.

Panel simTOUCH2:



Description of buttons:

1. Entering the MENU.
2. Button for selecting a parameter from the list, increasing the value of the edited parameter and switching main screens.
3. ENTER - confirmation.
4. EXIT - exit.
5. Button for selecting a parameter from the list, decreasing the value of the edited parameter and switching between main screens.

5.3. Switching controller on and off

Panel ecoTOUCH T4_RT:

After switching on the controller recalls its status from the moment of switching it off. If the controller was not active before, it will start in the "Stand-by" mode. In this mode it displays the current date and time, outdoor temperature and information: "Ventilation system turned off". To start the controller, press anywhere on the screen, then the following message will appear: "Turn on the controller?".



There is also another method of controller turn on or turn off. Press



menu button, find and press the symbol in the rotary menu. To turn off the controller, press the Menu button, then find

and press the symbol in the rotary menu.

Panel simTOUCH2:

After restarting, the regulator remembers the state in which it was before the moment of switching off. If the regulator has not operated before, it will start in the "standby" mode, in which the current time and date as well as the value of the external temperature are displayed with the information "Regulator off".



To start the regulator, touch the button , the message "Turn on the air handling unit?" will appear. Confirmation of the message with the button  will turn the regulator on again.

In order to switch off the regulator, touch the button  on any main screen and confirm deactivation of the regulator.

5.4. Main screens

Panel ecoTOUCH T4_RT:

The controller has two main screens. First: with the displayed parameters and operation modes, with the function of editing and reading information; second: with automation scheme displayed. The view between these screens can be switched.



Main screen with options to read information and change selected parameters.

Legend:

- 1. Settings for main mode and user modes.
- 2. Additional mode selection.
- 3. Main menu access.
- 4. Information field, e.g.: active alarms - press to display a list of all current alarms.
- 5. Schedules settings.
- 6. Switching between main screens.
- 7. Basic information – press to display all available information about controller operation status.

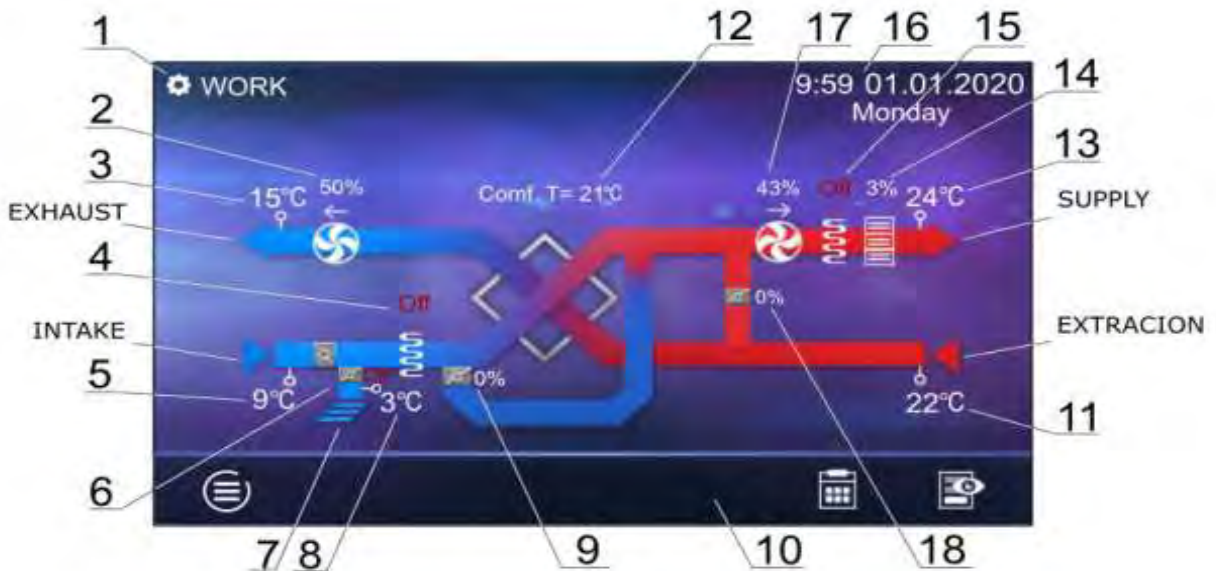

Main screen with cross-flow exchanger.



Automation schemes presented on the main screen can be different depending on whether there are individual ventilation system devices connected to the controller e.g.: throttles, heaters, and values display are for information purposes only.

Legend:

1. Regulation modes: OPERATION, OPERATION-Heating, OPERATION-Cooling, DEFROSTING, PAUSE, Exchanger cleaning, Heater cooling, Airing.
2. Exhaust fan adjustment.
3. Exhaust temperature.
4. Operation of the primary heater (electric or water).
5. Intake temperature (outdoor temp.).
6. Ground heat exchanger throttle actuator position (GHE).
7. Ground heat exchanger (GHE).
8. GHE temperature.
9. Bypass throttle actuator position.
10. Information:
 - [R1], [R2] – exceeding the demand for adjustment change threshold;
 - [FAS] – signal from the Fire Control System;
 - [ECO] – signal from the burglar alarm system;
 - [TR1] – primary heater thermostat input
 - [TR2] -secondary heater thermostat input
11. Extracted air temperature.
12. Comfort temperature (preset).

13. Supply air temperature.
14. Cooler work (Freon or water).
15. Working secondary heater (electrical or water).
16. Time and working day.
17. Air supply fan adjustment
18. Position of mixing chamber actuator.

Panel sim TOUCH2:

There are two main screens in the panel: an information screen with displayed values of basic parameters and a screen with displayed automation diagram. Switching between screens is done by touching the buttons (2) and (5).

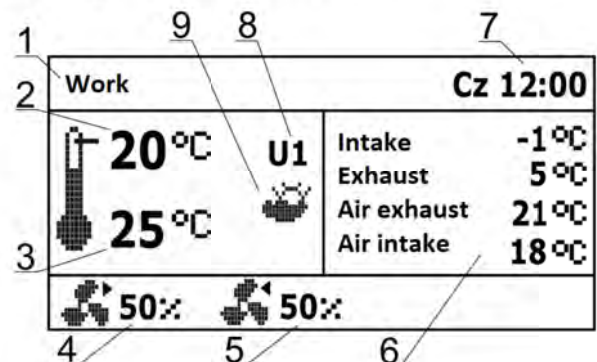

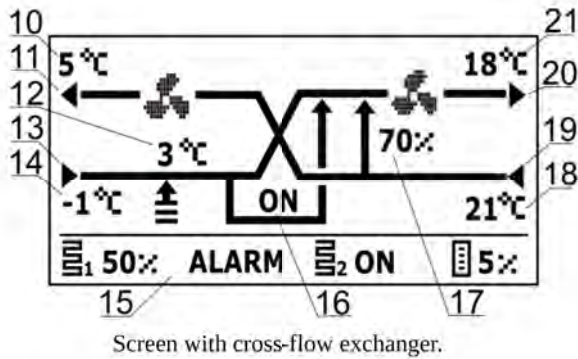

Information screen.





Legenda:

1. Regulation modes: OPERATION, OPERATION - Heating, OPERATION - Cooling, DEFROST, STOP, Cleaning the exchanger, Draining the exchanger, Cooling the heater, Airing.
2. Comfort temperature (set).
3. Regulation master temperature.
4. Supply fan status with current control.
5. Extract fan status with current control.
6. Information field of measured temperatures.
7. Day of the week and time.
8. Operation modes: Standstill, Mode 1... 4 (U1... 4).
9. Information field:

 - Summer mode active;

 - Winter mode active;

10. Exhaust temperature
11. Exhaust
12. GHE temperature and position of the GHE actuator:

 - OFF,  - ON.

13. Intake
14. Intake temperature (external).
15. Information field:

ALARM – alarm signaling;

 - primary heater operation;

 - secondary heater operation;

 - cooler work;

16. Bypass actuator position.
17. Mixer chamber actuator position.
18. Extract air temperature.
19. Exhaust.
20. Intake.
21. Supply air temperature.

5.5. Description of the controller's operation

5.5.1. Controller operation modes

The controller operation modes according to which ventilation is adjusted.

- OPERATION – the controller, using user settings, controls the ventilation to achieve the preset temperature in the room.
- OPERATION-Heating – the controller, disregarding low external temperature, seeks to keep preset temperature in the room; to achieve it first selects the source with the highest available air temperature, then depending on fulfilled conditions, starts secondary heater.
- OPERATION-Cooling - the controller, disregarding high external temperature, seeks to keep preset temperature in the room; to achieve it first selects the source with the lowest available air temperature, then depending on fulfilled conditions, starts the cooler.
- DEFROSTING – the controller prevents exchanger to freeze, by adjusting fans speed and starting primary heater or by opening bypass throttle.
- PAUSE – the controller stops ventilation system operation, only protection functions are operational.
- Exchanger cleaning - the controller activates the cleaning mode by switching fans to maximum power.
- Exchanger dehydration – controller starts exchanger dehydration function, while holding off fans operation.
- Heater cooling - the controller sustains air supply fan operation for a set time, to cool electric heaters.
- Airing - the controller turns on airing function.

5.5.2. Device operation modes

Settings regarding controller operation modes, according to which control will be performed, are in the menu:

Menu → Operation modes

The screen allowing setting of active controller functions is in the menu:

Menu → Operation modes → AHU operation modes

- *Main mode – AHU operation mode settings. Selecting Pause mode will stop ventilation system, only protection functions stay active. This mode can be applied to prevent unpleasant odors from the outside. It is possible to select one of modes Mode 1...4, settings of which can be defined by user.*

- *Time mode (Time operation mode) – turning on one of the additional AHU operation modes. Available settings:*

- Off: turn off active time mode.

- Out mode: holds on ventilation system operation, this mode can be applied e.g. for a period of leaving the room by user.

- Party mode: increases fans adjustment and amends preset temperature value, this mode can be applied e.g. during the presence of large number of people in the room.

- Airing mode: amends exhaust fan adjustment, while turning off air supply fan, this mode can be applied e.g. for fast air exchange in the room.

- Summer/Winter (Summer / Winter mode)
 - ventilation system control mechanism setting
 - Winter mode: blocks cooler and Bypass.
 - Auto mode: selection of active mechanism according to settings and external temperature
 - Ventilation: blocks cooler and heaters.
- Fireplace (Fireplace function support) – allows turning on fireplace function. If this function is ON, the control of exhausted air fan will be depending on supply air fan adjustment and preset difference in Speed parameter.
- Schedules – allows turning the controller on according to user defined schedules.

The screen allowing setting control mode is in the menu:

Menu → Operation modes → Summer/Winter

- Setting mode according to which the control will be performed. Similarly to **Summer/Winter** menu in **AHU operation mode menu**.
- *Winter mode turn on – outdoor temperature value below which, with auto mode active, winter mode will be turned on.*
- Hysteresis of summer mode on – hysteresis value of mode amendment, if auto mode is active and outdoor temperature increases above Winter mode turn on + Hysteresis of summer mode on the summer mode will be activated.

5.5.3. Settings of operating states

Settings related to operation modes, time modes and additional operating states of the controller, during which the control status of the ventilation system is changed for a specified period of time, can be found in the menu:

Menu → Operation modes → Work modes

- User modes settings – redirects to user
- modes settings, described in item *User modes*
- *Time modes settings – menu allows to define time modes settings, for Airing mode it is possible to set the duration time with Duration time parameter and adjusting exhaust fan with Speed parameter. For Party mode – duration with Duration time parameter, temperature preset with Comfort temp parameter, supply air fans adjustment with Supply air parameter and exhaust with Exhaust parameter. For Out mode it is possible to set its duration with Duration time parameter.*
- Schedules settings – redirects to schedules settings panel, described in item *Schedules*
- *Control leading sensor – setting, according to which sensor the preset temperature control is performed, available: Air control sensor, Exhaust sensor, Panel sensor (only ecoTOUCH panel).*
- Panel address – if leading sensor is set to panel sensor, then panel address, from which temperature value is read, must be set.

5.5.4. User modes

Menu allows individual setting, for each user mode 1...4, air supply speed (Air supply), exhaust speed (Exhaust) and preset temperature in Comfort temp. parameter.

5.5.5. Balanced ventilation function

The controller has balanced ventilation function that adjusts the flow of air and pressure in ventilation ducts. The function allows increasing the efficiency of heat recovery, immunizing the system against resistances e.g. due to air filter dirtying, exchanger resistances change due to humidity or dirt, starting air flow via ground heat exchanger.



The balanced ventilation function requires the connection of differential pressure sensors.

The function turn on and configuration is done in Installer menu.

5.5.6. GHE support

The controller supports ground heat exchanger (GHE) as a part of the ventilation system. The ground temperature is used here, which is more comfortable than outdoor air temperature for the most part of the year.



GHE support requires connection of additional temperature sensor.

The GHE settings parameter allows selection GHE operation mode:

- Close – the controller turn off glycol pump or closes the throttle cutting off the air flow via GHE.
- Open – the controller turn on glycol pump or opens the air throttle on the GHE canal.
- Auto - the controller turns on or off GHE depending on preset user settings, external temperature and GHE temperature. Turn on can be done in two modes: heating mode – winter turn on and in cooling mode – summer turn on. Winter turn on of GHE will be performed if outdoor temperature drops below Winter opening temp. and while GHE sensor temperature is higher than temperature on outdoor temperature sensor. Summer opening will be performed if outdoor temperature increases above Summer opening temp. and while GHE sensor temperature is lower than temperature on outdoor temperature sensor.



The outdoor temperature value is measured by a temperature sensor mounted on an intake.

In case of no GHE temperature sensor connected or its support is off in installer menu, the GHE control will depend on only from the outdoor temperature sensor readings.

Additional GHE control settings are in the menu:

Menu → GHE → Control settings

- *GHE max. opening time* – maximum duration of GHE throttle opening. After that time the GHE regeneration procedure will start.
- *GHE regeneration time* – duration of the GHE regeneration. During regeneration process the GHE throttle remains closed.
- *Manual start* – manual start of the regeneration without waiting for the fulfilment of the temperature and time condition.

5.5.7. Bypass support

The **Bypass** menu contains settings related to the bypass and allows selecting control type for the cross-flow exchanger bypass throttle. The throttle can be constantly open (Open parameter – no heat recovery and exchanger freezing risk), constantly closed (Close parameter) or in auto mode (Auto parameter), during which throttle will be open depending on fulfilment of open conditions. When bypass is open the inner rooms can be cooled to preset temperature using cooler air from the outside.

5.5.8. Burglar alarm system

After receiving signal of arming the burglar alarm system, the fans adjustment will be changed according to the following menu settings:

Menu → Burglar alarm system

- *Alarm system settings* – If the function is active, then after receiving signal from the burglar alarm system, the controller operation will be amended according to these settings.
- *Input logic state* – setting logical state of digital input: NC (normally closed) or NO (normally open).
- *AHU reaction* – setting the ventilation system reaction to received signal. If Turn off AHU is selected, then after receiving signal the device will be turned off. Otherwise, fans speed will be adjusted to the predefined settings with Exhaust and Supply parameters.
- *Airing* – turn on / off airing function, it works only with the burglar alarm system control mode on, and Turn off AHU option off.

The airing settings are in the following menu:

Menu → Burglar alarm system → Airing settings

- *Exhaust fan speed, Supply fan speed* – allow setting fans adjustment during airing.
- *Airing time* – parameter defining time, through which airing is performed.
- *Periodic airing time* – this parameter defines time periods between succeeding airing cycles.
- *Secondary heater work during airing* – turning on / off permission of secondary heater to work during airing.

5.5.9. Schedules

The menu allows to set the schedules of the ventilation system work.



Programmed schedule is stored in internal memory and is not deleted during the power outage.

Panel ecoTOUCH T4_RT:



Schedules support can be turned on in two ways: via Schedules parameter, in the menu

Menu → Operation modes → AHU operation modes

or via Schedules parameter, in the menu:

Menu → Operation modes → Work modes → Time schedule settings

In schedules menu: 5 time ranges of AHU work can be set for each day of the week (Time 1...5). For each range the duration time must be set (Start and Stop parameters: hours and minutes) and active work mode chosen (Mode parameter). If there is a time difference between ending of one range and beginning of another range, then during this time difference the controller will return to normally preset operation mode.



The button allows to copy currently defined schedule to any day of the week.

Panel simTOUCH2:

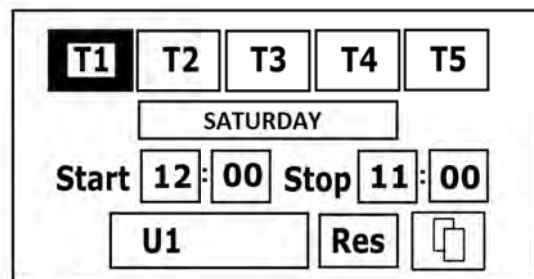

The scheduling mechanism can be enabled using the Schedules parameter located in the menu:

Menu → Operation modes → AHU operation modes

In the schedule menu located at the location:

Menu → Operation modes → Work modes → Time schedule settings

In schedules menu: 5 time ranges of AHU work can be set for each day of the week (Time 1...5). For each range the duration time must be set (Start and Stop parameters: hours and minutes) and active work mode chosen (Mode parameter). If there is a time difference between ending of one range and beginning of another range, then during this time difference the controller will return to normally preset operation mode.



The  button allows to copy currently defined schedule to any day of the week.

5.5.10. Filters replacement procedure

The controller alarms a need to replace air filters by constant alarm on the screen.



Filters replacement can be done only with power supply disconnected from ventilation system.

Procedure in case of dirtying filters depends on how controller was configured by installer. If installer enabled filters exchange for



user, when alarm triggers press  button, to start **Filters replacement procedure** and this will stop ventilation system. After displaying of active procedure alarm disconnect the ventilation system from electrical supply and replace the filters. After connecting the supply enter the following menu:

Menu → Filters → Filters replacement procedure, where class of new filters has to be selected (parameters: Air supply filter – class, Exhaust filter – class), and also confirm filters replacement (with parameters: Was air supply filter replaced?, Was exhaust filter



replaced?). After confirming filters replacement press  button, which allows return to Filters menu, and using Was filters replacement finished? parameter once again confirm finishing of filters replacement procedure, which erases alarms and allows further operation of ventilation system.

Filters can be also replaced before expiration of their exploitation period or before detecting their dirtying by the controller. To do so, enter the following menu:

Menu → Filters → Force filters replacement procedure and using Force filters replacement procedure manually start the replacement procedure.



If installer disabled filters replacement option for user, after triggering alarm of filters dirtying, call service.

5.5.11. Exchanger cleaning

The Cleaning start hour parameter allows setting the moment to start cleaning. The procedure will be started at the preset hour after reaching cleaning day.

5.5.12. General settings

The menu contains settings for user to set, related to general controller settings.

Panel ecoTOUCH T4_RT:

- Parental control – when turned on it blocks entering to the menu. Unlock by pressing the screen for 3 sec. (open padlock animation).
- Screen saver settings – setting Screen saver On / Off parameter to YES will dim or turn off the screen after set time. Time delay to start the screen saver is set with Time till screen saver parameter. The backlight value during active screen saver mode is set with Screen saver backlight parameter
- Button sound – enable or disable the sound while pressing the touch screen.
- Default settings – restores the default settings of the panel and controller parameters to the customer.
- Clock – setting the hour. Changing time in any room panel will trigger time change in the controller.
- Date – setting the date. After entering the date a day of the week will be set automatically.
- Brightness – allows changing screen brightness.
- Alarms sound – enable or disable alarms sound.
- Language – language selection.
- Software update - software update of controller module and control panel. Description later in the manual.
- ecoNET settings – a WiFi network configuration in case of connecting ecoNET300 internet module to the controller. SSID – network identifier must be entered, WiFi security chosen and password for selected WiFi network entered. Further module configuration should be carried out in accordance with operation and maintenance documentation for ecoNET300.

Panel simTOUCH2:

- Button sound – enable or disable the sound while pressing the touch screen.
- Alarms sound – enable or disable alarms sound.
- Screensaver settings - the time to start blanking is set in Time on ext. screen. In the parameter Screensaver mode, you can select the operation mode of the screensaver as Off, On or Clock.
- ecoNET settings – a WiFi network configuration in case of connecting ecoNET300 internet module to the controller. SSID – network identifier must be entered.
- Address settings - setting an individual address of the panel for correct communication with the module, in case of connecting subsequent panels.
- Brightness – allows changing screen brightness
- Contrast - screen contrast.
- Language – language selection.
- Clock – setting the hour. Changing time in any room panel will trigger time change in the controller.
- Date – setting the date. After entering the date a day of the week will be set automatically.

5.5.13. Cooperation with differential pressure sensors

The controller cooperates with external differential pressure sensor ecoPRESS-01. The transmission between sensor and the controller is in RS485 standard. Connecting the sensor enables additional parameters in service menu of the controller allowing configuration of sensor support. Data reading and configuration is done via ecoVENT controller and configuration parameters are placed in Installer menu.

5.5.14. Internet module cooperation

The ecoNET300 internet module enables remote maintenance of controller operation via Wi-Fi or LAN network, using www.econet24.com service.



To control the controller via connected internet module, it is necessary to connect control panel to the controller.

Using computer, tablet or smartphone with web browser installed or convenient application for mobile devices ecoNET.apk and ecoNET.app. user can remotely monitor the controller and modify its working parameters. The application can be downloaded free of charge from QR code below.



Android



iOS

GENERAL INFORMATION

The module enables remote management (on-line) of the regulators' operation.

www.econet24.com

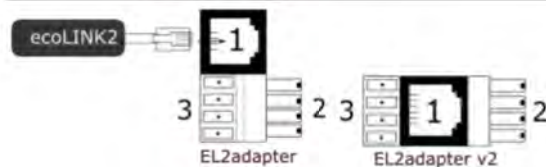
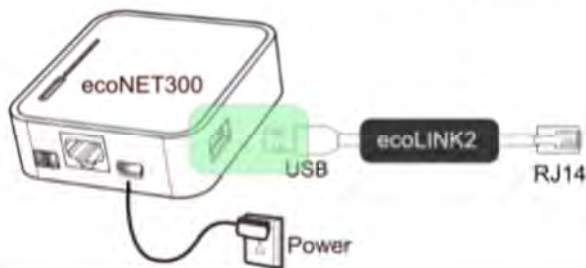

1- Socket for RJ14 ecoLINK2 interface, 2- A plug for controller module COM transmission socket, 3- Socket for a control panel plug (together with ecoSTER room panel).

CONNECTION WITH INTERNET NETWORK

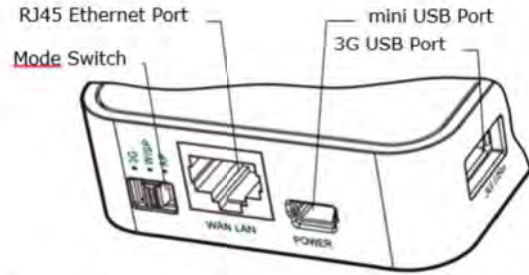

Connect the power adapter plug to the [mini USB Port] socket. We connect [3G USB Port] with the ecoLINK2 interface. Connect the [RJ45 Ethernet Port] socket with an Ethernet cable, eg to a router (the socket does not have to be used in the case of access to the Wi-Fi network). The [Mode Switch] switch can be set to any position.

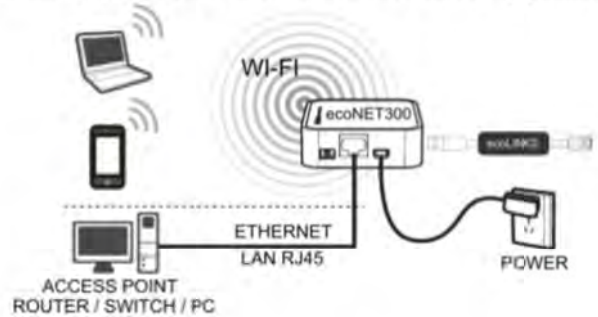

Deleting user name and password and restoring default settings. User: admin, password: admin. Works only in

LFD	Condition	ecoNET300 operation condition
Power	<input checked="" type="radio"/>	Power on
	<input type="radio"/>	Power off
Connection with a controller	<input checked="" type="radio"/>	Active connection of the controller.
	<input type="radio"/>	No connection with boiler controller.
Connection with WiFi	<input checked="" type="radio"/>	Connection to a programmed wireless network is on.
	<input type="radio"/>	No connection with wireless network.
Connection with a server	<input checked="" type="radio"/>	Connection with ecoNET24.com external server is on.
	<input type="radio"/>	No connection for ecoNET24.com external server.

After the power is on, ecoNET300 requires app. 1 minute in order to load the operational system. Then, the module begins to work and indicates its condition with LED indicators. In a connection between ecoNET300 module with a boiler controller is active, a  indicator lights up. New functions for managing ecoNET300 module are added to the main menu. EcoNET300 requires active DHCP server of Access Point (e.g. router) because manual IP assignment for ecoNET300 internet module is not supported. More information can be obtained from router configuration software or network administrator. In case of connection with a chosen Access Point via wireless network, user has to know the settings of WiFi network which the module will be connected to: network name (SSID), protection type, access password).

LOGGING INTO ecoNET ACCOUNT

In order to log in to the ecoNET account on the www.econet24.com server, you must provide your Login and Password.

FIRST LOGGING TO ecoNET

When logging in for the first time, you must first create a new account in the REGISTER tab, while the regulator must be powered on and properly connected to the module, and the module should be connected to the WiFi network and logged in to the server. From the ecoNET WiFi / Info tab in the main menu of the regulator, read and write down the UID number (the regulator's unique identification number):

MENU → Information → ecoNET WiFi

The read UID number should be entered in the REGISTER tab. If the system correctly verifies the UID number, the account registration form will be displayed. Fill in the form with the data of the regulator's user and enter the login password.

In a form field:

- Controller UID - is shown controller UID number. Correctness of the number UID is verified by the econet24 server.
- Regulator label – enter a name of your controller.
- Remote access to the controller by the service and the producer – enables to access and edit controller parameters via service and boiler manufacturer.
- Regulator installation address (Similar as user address) – Check this field if the controller address is the same as residential address.
- Enable sending alarm notices on e-mail) – In case an alert occurs, an alarm message including alarm contents will be sent. On previously entered e-mail address.

Obligatory fields: E-mail, Password, password (again), UID identifier of the controller.

A WEBSITE FOR MANAGING OPERATION OF THE CONTROLLER

- Current data - Current readout of the boiler controller operation condition data and possibility of changing its parameters.
- Diagram - Graphical representation of hydraulic diagram of installation with current operation condition readout for its particular elements.

- User parameters - Detailed readout and modification of operation parameters of the boiler controller.
- Service parameters - Readout and modification of all parameters of the boiler controller and CH/HUW installation.
- Data history - Data archive of selected controller operation parameters. Tab available only in a service version.
- Alarms - List of boiler controller alarms.
- Schedule - regulator work schedule and temperature drops
- Device settings - Information concerning boiler controller and additional modules, possibility of changing address and service password.

The **Current data** tab shows the tiles with the values of the basic parameters of the regulator's operation. The parameter to be

modified is marked with the symbol . Just click on this tile and a value change window will appear, in which you can set a new parameter value using the slider and confirm with the Save button.

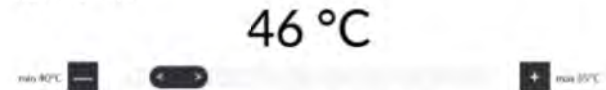

To exit the modification, without saving the new setting, click the symbol .

The Scheme tab shows the scheme connecting the regulator with the installation, with the readout of sensor parameters at its

individual points. A parameter to be modified is indicated by . Click a tile and Modify value window will appear. Enter new value, e.g. Boiler temperature and confirm with save button. To exit the modification, without saving the new setting, click the

symbol . Basic parameters of controller operation are displayed in "User parameters" tab. These parameters are grouped and all can be modified by the user. Advanced parameters are displayed in the Service parameters tab and can only be modified after entering the password. All displayed parameters are grouped appropriately. Clicking on the name of the selected group of parameters will expand the list of available parameters. Parameters to be modified are marked with the symbol. To change, click on the selected parameter and then in the additional window that appears, set the new parameter value with the slider and confirm with the Save button. To exit the modification, without saving the new

setting, click the symbol . "Data history" tab, only in server version, enables to readout registered parameters concerning operation of the whole heating system in a selected time and present it in the form of a graph. Choose a time period for data readout by clicking From: or To: (select date and time in a calendar). Confirm with Done. Then, from the list below the graph, select the parameters that will be displayed on this graph. By marking the selected time area on the graph, you can "scale" this area to a more precise one. Additionally, clicking on the symbol causes that "nodes" are displayed on the chart. This is information about the time and value of a single data sample sent by the regulator to the econet24 website.

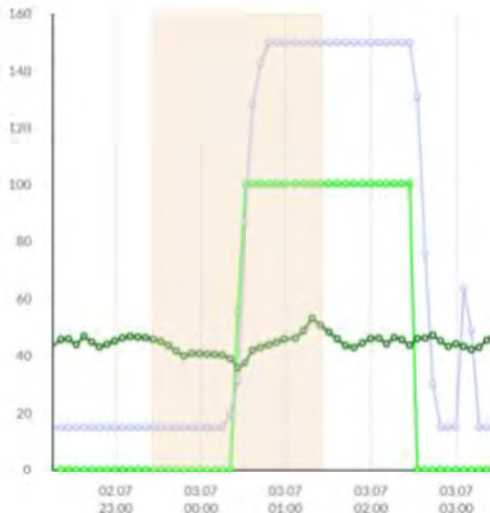

The return to the initial chart is done by pressing the icon . Data from the chart can be saved as a *.csv or *.png file after

pressing the icon . In the Alarms tab, you can view the list of registered alarms and other events sent to the server by the regulator. The list displays the type of alarm / event as well as the date and time of its occurrence. When logging in to the www.econet24.com server, all logs of alarm states from the beginning of the regulator's operation are displayed. Alarm messages can be sent to an e-mail, which enables the user to quickly intervene in order to restore the proper operation of the regulator. In the Schedule tab, the possibility to set time intervals has been introduced, according to the list after clicking the symbol



For the available circulation from the list, activate the schedule by selecting On and enter the value of the reduction temperature in the Reduction field, eg 10°C. On the daily bar chart (24h), click on the appropriate bars (each bar corresponds to 30 minutes), which allows you to set an active reduction in the selected time period. After setting, choose Save. The set temperature reduction can be set separately for all days of the week.



In the above example, on Tuesday, the preset temperature for the heating circuit is decreased by 10°C in the range from 6 a.m. until 7:30 a.m. and from 3:30 p.m. till 7:00 p.m .. In other intervals, the preset temperature will not be decreased.

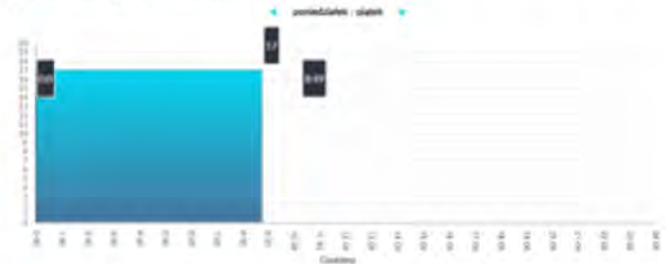

In the Fuel consumption tab, you can read the fuel consumption in kg in detail from the graph in a daily (every 1h) or monthly (every 1 day) cycle.

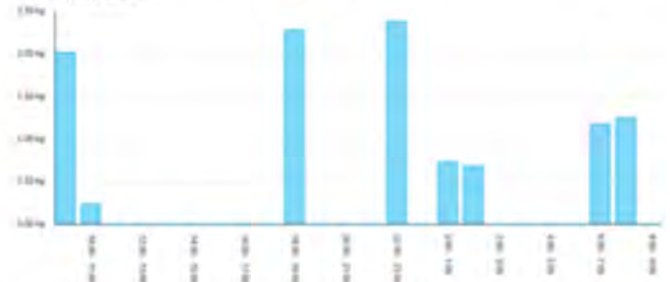

The Device settings tab allows you to change the address of the controller installation, read the WiFi network parameters, read the controller program version and update the module software. The econet24 server periodically checks the availability of a new software version for the module. In the tab, it displays information about the new version of the program - just press Update. During the module firmware update, the module power supply must not be turned off, as this will damage it. When changing the WiFi network, press the Refresh button, then select the Network Name from the list, select the used Security Type from the list, eg WPA2, and enter the Password for the selected network. Any changes to the settings should be confirmed by selecting Save.

RESTORING THE DEFAULT USERNAME AND PASSWORD

Restoring the default username and password to: user - admin, password - admin can be done using the WPS / RESET button located next to the LEDs of the module housing.

1) During normal operation of the module, press and hold the WPS / RESET button for 10 seconds



2) After releasing the button, the LED diode next to the button should flash several times.



3) Wait about 2 minutes.

4) After this time, the module will restart automatically and will connect to the WiFi network.

5) Default username and password will be restored.

THE MOBILE APP

The mobile application allows remote access via smartphone only to the regulators equipped with the ecoNET300 module and cooperates with the www.econet24.com website, therefore, in order to use it, you must create an ecoNET account. The application for Android and iOS can be downloaded from the QR code below.



ecoNET.apk
Android



ecoNET.app
iOS

5.5.15. Alarms and prompts



Working in the emergency state is allowed only under your supervision until the arrival of the service and rectify the fault. If the user's supervision is not possible, the controller should be disconnected from the power supply.

Alarm	Possible cause	Due to an alarm	Display
Error supply air temperature sensor	The sensor is defective, or not properly connected or not configured	Signaling alarm, stopping ventilation system	Continually since the occurrence of the cause of the alarm, then the disappearance of the alarm.
Error temperature after exchanger			
Error exhaust temperature sensor			
Error outdoor temperature sensor			
Error extraction temperature sensor			
Error GHE temperature sensor			
Error leading temperature sensor	Leading sensor is damaged, falsely connected or not configured.	Signaling alarm, stopping ventilation system	Continually since the occurrence of the cause of the alarm, then the disappearance of the FAS alarm.

Active FAS alarm	FAS Alarm - ventilation system stopped due to external signal	Signaling alarm, procedure supporting FAS	Continually since the occurrence of the cause of the alarm, then the disappearance of the FAS alarm.
General inspection by manufacturer's service required	General inspection required contact manufacturer's service department	Signaling alarm, ALARM output active	Until entering new inspection date by the Installer
Filter dirty – operating period expired, contact service	Filter might be dirty – call service to replace filters.	Signaling alarm, no display of energy recovery	Until new inspection date is entered by the installer
Too high room supply air temp.	Detected too high room supply air temp.	Signaling alarm, ALARM output active, protection procedure against too high temperature started	Continually since the occurrence of the cause of the alarm
Too low room supply air temp.	Detected too low room supply air temp.	ALARM output active, protection procedure against too low temperature started	Continually since the occurrence of the cause of the alarm
Primary water heater thermostat operation noticed – soaking process started	Primary water heater thermostat operation signal noticed – soaking process started	Signaling alarm, ALARM output active, soaking procedure	Continually since the occurrence of the cause of the alarm
Secondary water heater thermostat operation noticed – soaking process started	Low temperature or signal from secondary water heater thermostat noticed - soaking procedure started	Signaling alarm, ALARM output active, soaking procedure	Continually since the occurrence of the cause of the alarm
Possible secondary heater overheat	Secondary electric heater thermostat trip noticed. Possible need of reset.	Signaling alarm, ALARM output active, soaking procedure	Continually since the occurrence of the cause of the alarm
Secondary heater overheat – 3x thermostat trip	High secondary electric heater temperature – triple thermostat trip. Too low air flow, heater thermostat may require alarm confirmation	Signaling alarm, ALARM output active, ventilation system operation stopped	Continually since the occurrence of the cause of the alarm
Periodic inspection approaches	Periodic inspection approaches – contact service	Signaling alarm, ALARM output active, ventilation system operation stopped	Continually since the occurrence of the cause of the alarm
Heaters thermostat operation noticed	Heaters thermostat operation noticed. Reset may be required.	Signaling alarm, ALARM output active, ventilation system operation stopped	Continually since the occurrence of the cause of the alarm
Heaters thermostat operation noticed three times – confirmation required	High temperature of electric heater - Heaters thermostat operation noticed three times. Too low airflow, heater thermostat may require alarm confirmation.	Signaling alarm, ALARM output active, ventilation system operation stopped	Continually since the occurrence of the cause of the alarm
Installer settings error. Possible erase of settings	Deletion or no settings acknowledgement in service menu	Signaling alarm, ALARM output active, ventilation system operation stopped	Continually since the occurrence of the cause of the alarm
Manufacturer settings error, possible settings deletion	Deletion or no settings acknowledgement in service menu deletion	Signaling alarm, ALARM output active, ventilation system operation stopped	Continually since the occurrence of the cause of the alarm
Device locked – unauthorized start-up	Unauthorized device configuration attempt	Signaling alarm, stopping and blocking ventilation system	Continually since the occurrence of the cause of the alarm
No communication with the controller.	Possible damage to the transmission cable connecting the panel with the controller.	Signaling alarm, further work of the ventilation system.	Continually since the occurrence of the cause of the alarm
No communication with pressure/flow sensor for air supply	Communication error between controller and pressure/flow sensor for air supply duct. Possible damage or improper sensor connection.	Signaling alarm, further work of the ventilation system.	Continually since the occurrence of the cause of the alarm
No communication with pressure/flow sensor for exhaust	Communication error between controller and pressure/flow sensor for exhaust duct. Possible damage or improper sensor connection.	Signaling alarm, further work of the ventilation system.	Continually since the occurrence of the cause of the alarm
Air supply filter replacement deadline approaching	The air supply filter counter exceeded value preset with Filter replacement deadline alarm.	Signaling alarm	Continually since the occurrence of the cause of the alarm
Exhaust filter replacement	The exhaust filter counter exceeded	Signaling alarm	Continually since the occurrence of

deadline approaching	value preset with Filter replacement deadline alarm.		the cause of the alarm
Air supply filter dirtying - turn off ventilation system and replace filter	Possible air supply filter dirtying – replace filter. Alarm available if filter replacement is available for user.	Signaling alarm, ALARM output active	Continually since the occurrence of the cause of the alarm. After alarm acceptance filter replacement procedure starts.
Exhaust filter dirtying - turn off ventilation system and replace filter	Possible exhaust filter dirtying – replace filter. Alarm available if filter replacement is available for user.	Signaling alarm, ALARM output active	Continually since the occurrence of the cause of the alarm. After alarm acceptance filter replacement procedure starts.
Air supply filter dirtying – call service	Possible air supply filter dirtying – call service for filter replacement.	Signaling alarm, ALARM output active	Continually since the occurrence of the cause of the alarm
Exhaust filter dirtying – call service	Possible exhaust filter dirtying – call service for filter replacement.	Signaling alarm, ALARM output active	Continually since the occurrence of the cause of the alarm
Filters replacement procedure	Alarm after overriding filters replacement procedure.	Signaling alarm, ventilation system operation stops.	Continually since the occurrence of the cause of the alarm
Emergency mode – filters worn out	Alarm in case of filters worn out and with ventilation system operational in emergency mode.	Signaling alarm, ALARM output active; if emergency mode is OFF then controller turns off	Continually since the occurrence of the cause of the alarm
Air supply fan operation confirmation error	Possible mechanical fan damage. Turn off ventilation system and contact service.	Signaling alarm, ALARM output active.	Continually since the occurrence of the cause of the alarm
Exhaust fan operation confirmation error	Possible mechanical fan damage. Turn off ventilation system and contact service	Signaling alarm, ALARM output active.	Continually since the occurrence of the cause of the alarm
Filters dirtying test – do not turn off the system	Starting filters dirtying test procedure.	Signaling alarm.	Continually since the occurrence of the cause of the alarm
Communication error with ecoPRESS 1 -4 sensor	Communication with one of ecoPRESS sensors lost (each sensor generates separate alarm).	Signaling alarm.	Continually since the occurrence of the cause of the alarm
ecoPRESS 1 – 4 sensor internal error	Connected ecoPRESS sensor has been damaged or improperly configured (each sensor generates separate alarm).	Signaling alarm.	Continually since the occurrence of the cause of the alarm

5.5.16. Cooperation with air parameters sensors

The controller has integrated software modules allowing cooperation of recuperation central with selected types of air parameters sensors: digital carbon dioxide level sensor (CO₂), analog carbon dioxide level sensor (CO₂) or analog humidity sensor.

Humidity and CO₂ level threshold sensors

Humidity and CO₂ level threshold sensors are made to constantly monitor concentration of carbon dioxide in the room. With the moment of exceeding a preset CO₂ value sensor contact output status changes. Controller responds on this status change by proper adjustment of fans speed: air supply and exhaust. It provides faster air exchange in the room, which results in lowering carbon dioxide concentration in the air. After stopping the signal from the sensor and passing the support time controller sets fans speed according with chosen operation mode.



Settings regarding support of digital sensor, fans speed override and support time are in the installer menu and should be adjusted during installation of ventilation system.

Analog CO₂ level sensor

Analog CO₂ level sensor is made to constantly monitor concentration of carbon dioxide in the room. If the sensor detects high CO₂ concentration the controller will immediately override

fans speed. It will provide faster air exchange in the room, which results in lowering carbon dioxide concentration in the air. However, if the sensor detects too low CO₂ concentration, controller will immediately lower fans speed. It will provide lowering the amount of outdoor air intake, resulting in successive increase of CO₂ concentration. When CO₂ concentration in the air reaches nominal value the controller will get back to normal operation mode and set fans speeds according to currently selected operation mode.



Settings regarding operation of analog CO₂ sensor are in installer menu and should be adjusted during installation of recuperation central.

Analog humidity sensor

Analog humidity sensor is made to constantly monitor concentration of water vapor in the room. If the sensor detects too high humidity level, controller will immediately override increase of fans speed. It will provide faster air exchange in the room resulting in fast humidity excess removal. However, if the sensor detects too low humidity, the controller will immediately override lowering fans speed. This will provide in lowering outdoor air intake resulting in increasing humidity. When humidity level reaches nominal value the controller will get back to normal operation mode and set fans speeds according to currently selected operation mode.



Settings regarding operation of analog humidity sensor are in installer menu and should be adjusted during installation of recuperation

6. Installation and service settings

6.1. General Information

The installation of the recuperator should be carried out by a qualified installer with electrical qualifications SEP G1E 2 (Devices, installations and power networks with a voltage not higher than 1kV). The ventilation installation should be carried out in accordance with the industry design. Work must be carried out in accordance with applicable industry regulations and in accordance with the principles of occupational health and safety.



Before connecting the ventilation ducts, the AHU's connection stubs must be blinded. Damage caused by dirt and foreign bodies is not covered by the warranty.

When connecting the ventilation ducts, pay attention to the direction of the air flow. It is recommended that the ventilation system be equipped with:

- inspection hatches for inspection and cleaning of the installation,
- shut-off dampers on the intake and exhaust duct,
- acoustic silencers on the supply and exhaust air main duct.

It is recommended to connect the air handling unit to the installation with a round SPIRO cable with a diameter of $d = 180$ mm. If the unit is connected with flexible ducts or attenuator, the length of each flexible element should not exceed 1 meter. Ventilation ducts should be installed on supports carrying their total weight.



It is forbidden to perform the installation in a way that will transfer the loads caused by the weight of the installation through the connections of the air handling unit.

The AHU and ventilation ducts should be installed in a way that allows maintenance and service work to be carried out, keeping distances allowing for possible disassembly of the ducts.

The air handling unit, depending on the set operating parameters, can transmit noise and vibrations, therefore it is recommended to install the device in a room where the generated noise will not be significant for the user. In order to ensure the highest possible comfort of use, it is also recommended to use duct installation silencers.

The installation should be insulated in accordance with applicable regulations and industry guidelines.

6.2. Place of installation

The air handling unit should be installed in a heated room where, regardless of the season, the minimum temperature will not fall below $+ 5 \text{ }^\circ \text{C}$, and the maximum relative air humidity will not exceed **70%**.

It is recommended to install the device in utility rooms, garages, basements and in insulated attics of single-family houses.

central.



The device should not be installed in rooms with high humidity gains, such as laundries and drying rooms.

A socket outlet must be provided near the device. The control panel is equipped with a 3 m long power cord. It is not allowed to power the control panel through extension cords or installation distributors.

A place should be provided in the room for connecting the condensate drain to the sewage system.

6.3. Installation of the device

6.3.1. Minimum distances and service space

When choosing the place of installation of the recuperator, the required minimum distances necessary for maintenance and service should be kept:

- minimum distance in front of the device: 1000 mm
- minimum distance from the ceiling: 200 mm
- minimum distance from walls: 20 mm
- minimum distance from the floor: 220 mm (depending on the provided condensate drainage system).

6.3.2. Wall mounting

The suspended mounting kit includes:

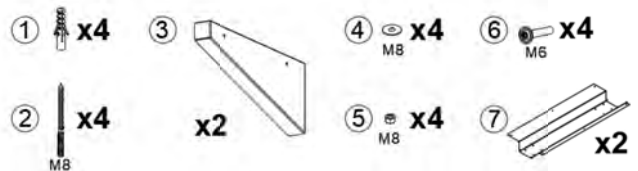

1. Mounting pin (x4)
2. Double-threaded screws M8 (x4)
3. Air handling unit bracket (x2)
4. M8 washer (x4)
5. M8 self-locking hexagonal nut (x4)
6. M6 screw (x4)
7. Mounting bracket (x2)



Before starting the assembly, check the completeness of the delivery.

The recuperator should be mounted on a wall with a structure that allows to transfer loads, it is recommended to mount it on a load-bearing wall. The manufacturer does not allow direct installation of the device on a plaster wall or a skeleton wall.

The recuperator should be installed on previously leveled mounting brackets, available as additional equipment. The manufacturer is not responsible for any damage caused by the use of inappropriate brackets. Before starting work, make sure that the plugs and screws supplied with the device are suitable for use in the room wall. In the event that the materials used or the technology of making the wall require the use of a different fixing system, the provision of appropriate elements of the mounting system is the responsibility of the person conducting the installation work.

Installation should begin with the safe position of the unit on one of its sides. Next, screw **two mounting brackets** to the control panel bottom plate in the holes as shown in the drawing, using M4 mounting screws, 6 screws for each bracket. Make sure that the sloping part of the mounting brackets is directed outside the unit.

Then, you can proceed to mounting the wall brackets, starting with mounting **the mounting pins (1)**. It is required to provide spacing between supports equal to 470 mm. After inserting the **pins (1)**, screw in **the double-threaded screws (2)**. The screws should be tightened with a Torx size 25 screwdriver. Using the screws, attach **the brackets (3)**, and then fix them with the provided **M8 washers (4)** and **M8 self-locking nuts (5)**.

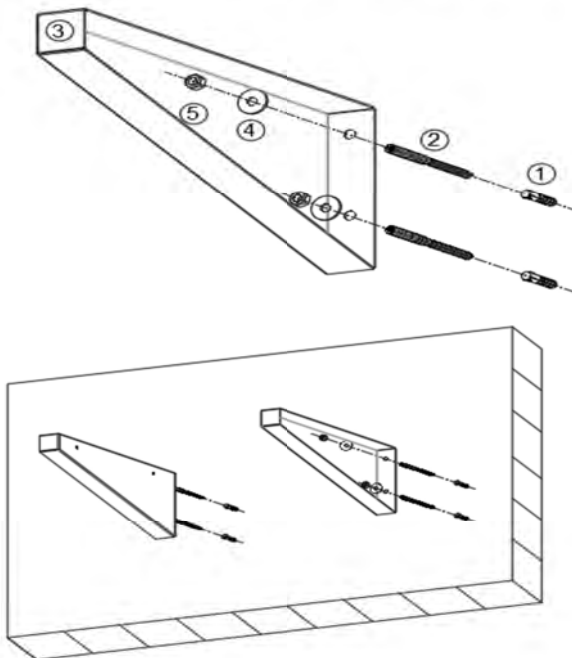

After mounting and leveling the brackets, place the control unit on them. The previously mounted brackets for the control panel have mounting points that should be used to immobilize the control panel using the **M6 screws** included in the kit.

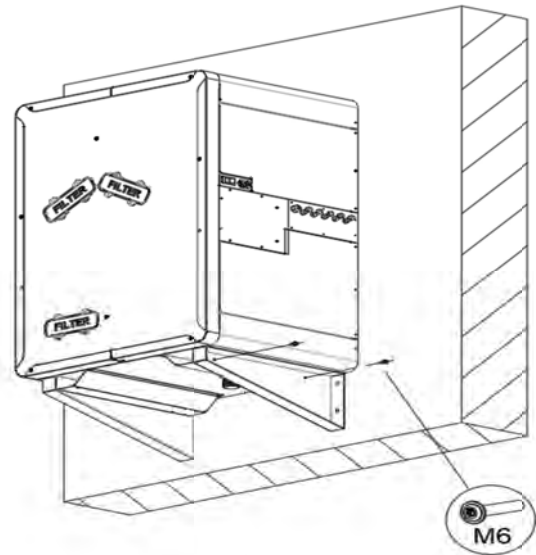

In order to reduce possible vibrations coming from the ventilation system, it is allowed to cover the upper surface of the supports with a damper tape.

After completing the AHU assembly, install the siphon in accordance with the instructions in chapter Connecting the condensate drain.

6.3.3. Installation on the floor of the room

Installation of the air handling unit on the floor of the room requires prior assembly of the supplied assembly kit. The set for standing assembly of VS recuperators includes:

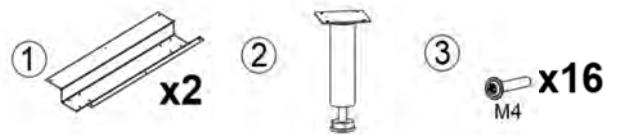

1. Mounting brackets (x2)
2. Adjustable mounting foot (x4)
3. Mounting bolts of the M4 brackets (x12)
4. M4 mounting feet mounting screws (x16)

i Before starting the assembly, check the completeness of the delivery.

Mounting the standing console:

Installation of the standing console should begin with the safe position of the control panel on one of its sides. Next, screw **two mounting brackets** to the control panel bottom plate in the holes as shown in the drawing, using M4 mounting screws, 6 screws for each bracket. Make sure that the sloping part of the mounting brackets is directed outside the unit.

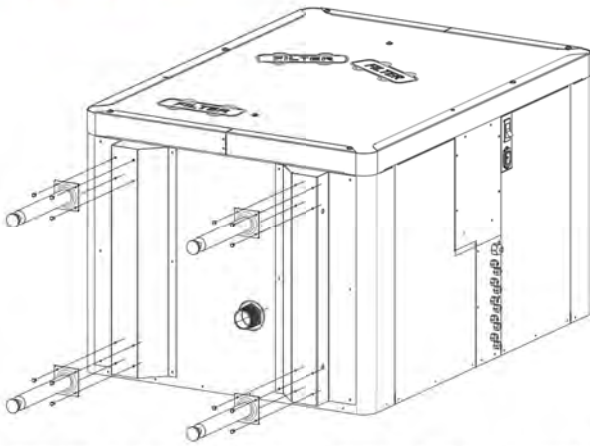

The next step is to mount the four mounting feet to the previously mounted mounting brackets using M4 mounting screws

Then, turn the air handling unit and put it in its target place, remembering to level it using the leveling feet.

Positioning and assembly of the air handling unit:

The assembled unit with supports should be placed on a solid, level ground, in the place where it is planned to connect the air handling unit to the installation. Then make sure that the control panel is level. The difference in levels can be compensated by the use of adjustable mounting feet.

After completing the AHU assembly, install the siphon in accordance with the instructions in chapter Connecting the condensate drain .

6.4. Connecting the condensate drain

Correct operation of the air handling unit requires a condensate drainage system. The factory-made mounting hole for the condensate drain is located in the drip tray in the center of the unit base.

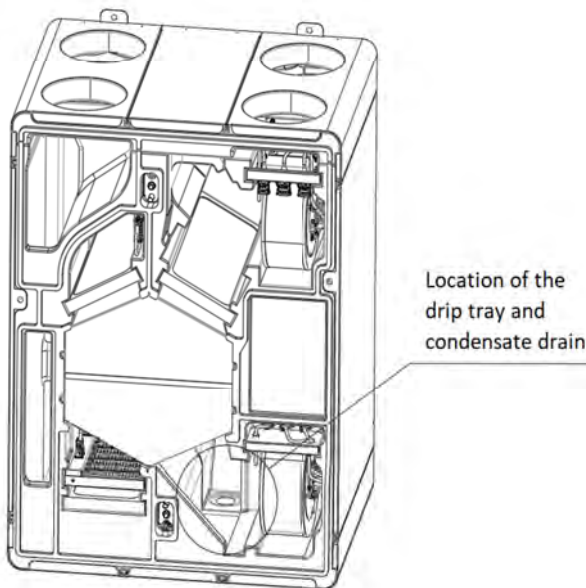

Installing the condensate drain:

A washbasin siphon with aeration, available as an accessory, should be connected to the drain socket, which should then be connected

to the condensate drain system. The siphon is adapted to be connected to a plastic pipe with a diameter of DN 32. It is recommended to install the condensate drainage pipe with a 1 - 3% slope. After completing the installation, the AHU's drip tray should be filled with water and the proper operation of the condensate drainage system should be checked.

The correct way to install the condensate drain is shown in the figures below:

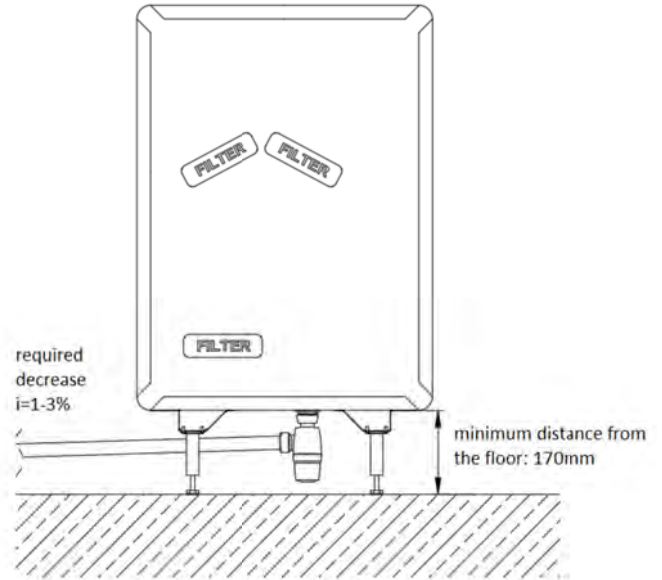

Correct installation of the condensate drain for the VS AHU installed on the floor of the room

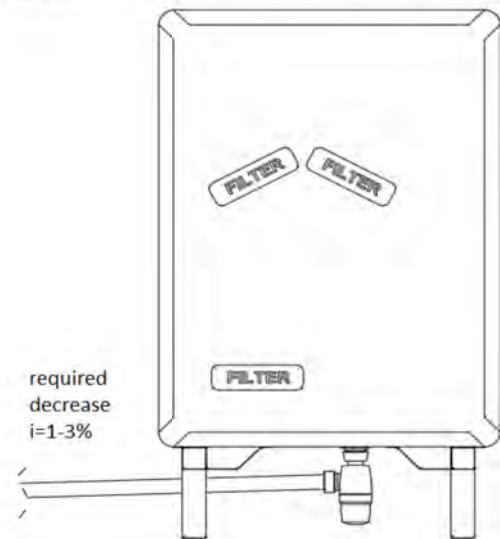

Correct installation of the condensate drain for the VS AHU installed on the room wall

6.5. Connecting the air handling unit to ventilation ducts

Ventilation installation, including:

- channel diameters or sections,
- regulation equipment and silencers,
- installation routing,
- duct insulation,

should be made in accordance with a previously developed industry project and applicable regulations.

The ducts connected to the AHU should be equipped with fasteners in a way that will protect the installation against vibrations and noise transmission, e.g. by using mounting clamps with a gasket.

It is recommended to install silencers in order to avoid transmission of noise and vibrations to the ventilation ducts and devices. It is also necessary to provide an inspection area for inspection and cleaning of the pipes in order to protect the AHU against excessive wear of the filters.

All ventilation ducts connecting with the AHU must have nominal diameters of $d = 200$ mm. The ducts must be carefully protected with a vapor-tight thermal insulation up to the housing of the device. It is recommended that the distance between the connection to the unit and the nearest branch or elbow is not less than three times the diameter of the ventilation duct, however, the work should be carried out in accordance with the design, which may provide otherwise.

Duct connections should be made in a way that ensures their tightness.

The air intake and launcher should be equipped with a net protecting the installation against insects.

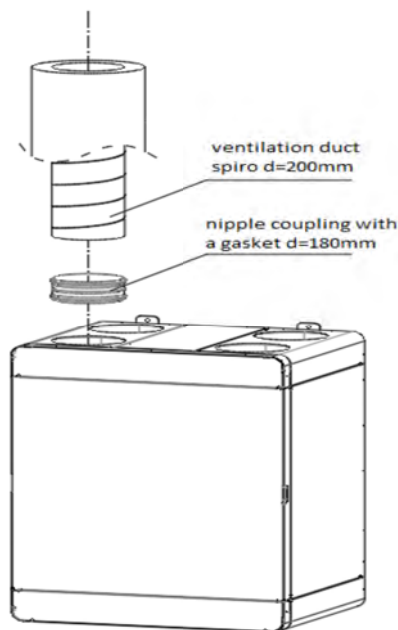

The connection of the installation with the AHU should be made with the use of nipple couplings with a gasket, which will allow for a tight connection with the beginning of the installation. The insulation of the intake and exhaust ducts should be led as far as the device.

Additionally, it is recommended to insulate the supply and exhaust air ducts.

After completing the assembly works, adjust the installation in accordance with the information included in the design.



It is forbidden to connect a duct connected to the kitchen hood to the unit.



The ventilation ducts should be based on the load-bearing elements of the installation. It is forbidden to rest the weight of the ventilation ducts on the AHU connections.

6.6. Connecting the electric installation and control system

Connection of the device with the electrical system, in accordance with the applicable safety rules, should be performed by a qualified installer. The installation parameters must comply with those indicated by the Manufacturer in the attached technical documentation and on the rating plate located on the device housing. The device must be connected to the grounding system.

The device must be connected directly to a power socket which must be easily accessible for the entire service life. It is forbidden to power the device with extension cords or voltage distributors. The connection is made using the power cord with the C19 connector, which is part of the standard delivery. A damaged power cord may only be replaced by a qualified specialist, taking into account the rated operating parameters given by the Manufacturer.

The device is disconnected from the mains by means of a two-pole switch located on the controller housing. The C19 connector used for the power cable has an integrated anti-current protection (16A) and a built-in EMC filter.

For the sake of safe use and maintenance and service work, the Device should be connected to a separate circuit of the facility's electrical system, similarly to the circuits for a washing machine, refrigerator or lighting. The circuit to which the device is connected must be protected with a residual current device with overcurrent protection B16, according to the diagram presented in this chapter. Before connecting the device to the power supply, check the device, paying particular attention to possible damage caused during assembly works.



The device should be connected to the power supply and started up after the completion of installation and finishing works.



The manufacturer is not responsible for personal injury and property damage resulting from failure to comply with the installation and operating instructions.

Connecting the controller panel:

The control panel is designed to be mounted on a wall or placed on a flat surface, only in a dry room. The panel cannot be used in the presence of water vapor condensation and cannot be protected from the action of water. The panel should be mounted at a height that allows convenient operation, typically 1.5 m above the floor in a room with a relative humidity level not exceeding 70%.

In order to reduce the interference of temperature measurement by the panel, avoid places with strong sunlight, poor air circulation, close to heating devices and directly next to doors and windows (typically at least 200 mm from the edge of the door).

The VS series recuperator controller panel should be connected to the control panel with the LIY 4 x0.5 mm² cable plugged into the COM1 transmission channel socket. The maximum cable length is 100 m.

The panel is powered by the controller installed in the control panel and does not require additional power supply. Detailed installation is included in the controller manual.

Connecting the WIFI ecoNET module

The WIFI module of the VS series recuperator should be installed in the place indicated by the user. The location must allow free communication between the device and the WiFi router ("good

range" of the WIFI network). The module should be connected to the control panel. Connect the RJ11 cable to the control panel, then lead it to the room where the WIFI module is to be installed. A factory RJ11 / USB cable is required to install the WIFI module. In the control panel installation room and the module installation room, it is recommended to prepare RJ11 sockets connected with appropriate cables, which will facilitate the installation work.

Connection with the BMS system:

The controller has a built-in software module that allows communication using the Modbus RTU protocol. Instructions and details on integration with the BMS system are included in the controller manual.

6.7. Connecting the electric installation and control system

6.7.1. Central control according to demand

The control is available in the following models of recuperators:

Secondary, Water Heat Exchanger	Exchanger and connection side		
	Temperature	Enthalpy	Hybrid
Central control according to demand (monochrome, built-in touch panel)			
N/A	VST 400	VSE 250	VSH 400
Heater	VST 400 H	VSE 250 H	VSH 400 H

Installation diagram for devices without a built-in heater or cooler:

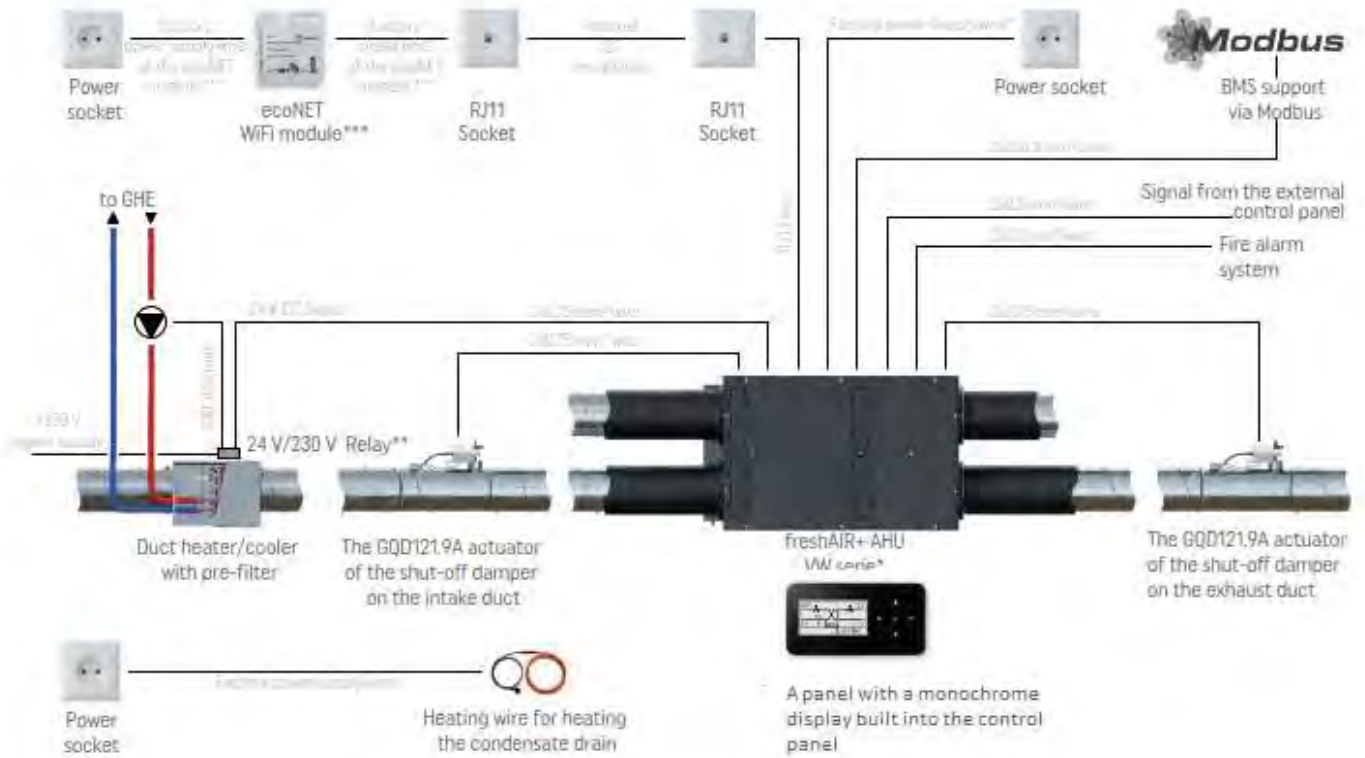

* - Standard scope of delivery for a heat recovery unit. The supply socket for the air handling unit should be made on a separate electric circuit equipped with a residual current circuit breaker of min. 16A. The maximum length of the given cables is 50 m.

** - The controller controls the operation of the GHE pump through a 24 V / 230 V relay located in an electrical box located on the duct preliminary heater.

6.7.2. Central control according to demand

The control is available in the following models of recuperators:

Secondary, Water Heat Exchanger	Exchanger and connection side		
	Temperature	Enthalpy	Hybrid
Central control according to demand (color, wall panel and humidity sensor)			
N/A	VST 400 +	VSE 250 +	VSH 400 +
Heater	VST 400 H+	VSE 250 H+	VSH 400 H+

Installation diagram for devices without a built-in heater or cooler:

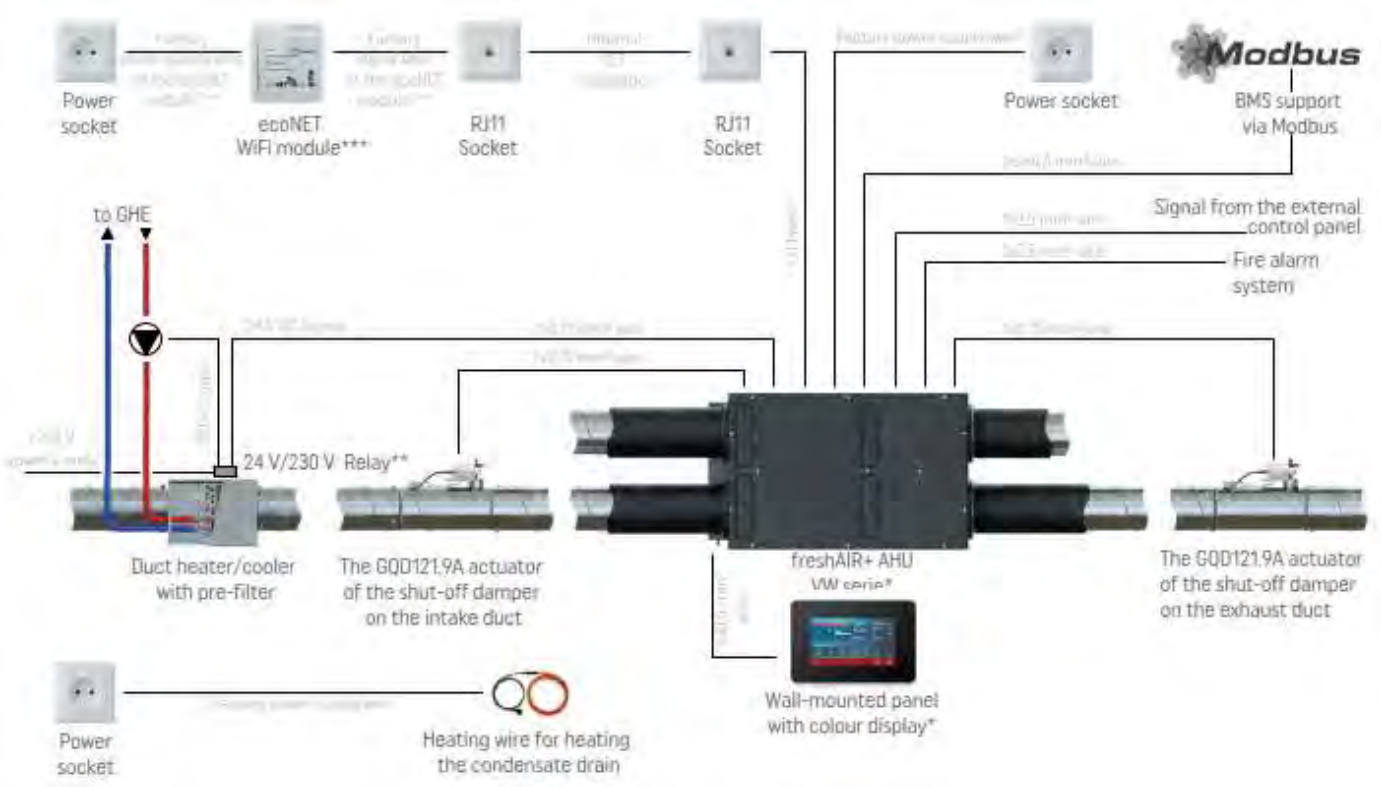

* - Standard scope of delivery for a heat recovery unit. The supply socket for the air handling unit should be made on a separate electric circuit equipped with a residual current circuit breaker of min. 16A. The maximum length of the given cables is 50 m. The humidity sensor is built into the control panel.

** - The controller controls the operation of the GHE pump through a 24 V / 230 V relay located in an electrical box located on the duct preliminary heater.

6.7.3. Local control according to demand (DCV)

Local control according to demand is available in the following models of recuperators:

Secondary, Water Heat Exchanger	Exchanger and connection side		
	Temperature	Enthalpy	Hybrid
	Local control according to demand (color, wall panel and humidity sensor)		
N/A	VST 400 DCV	VSE 250 DCV	VSH 400 DCV
Heater	VST 400 H DCV	VSE 250 H DCV	VSH 400 H DCV

Installation diagram for devices without a built-in heater or cooler:

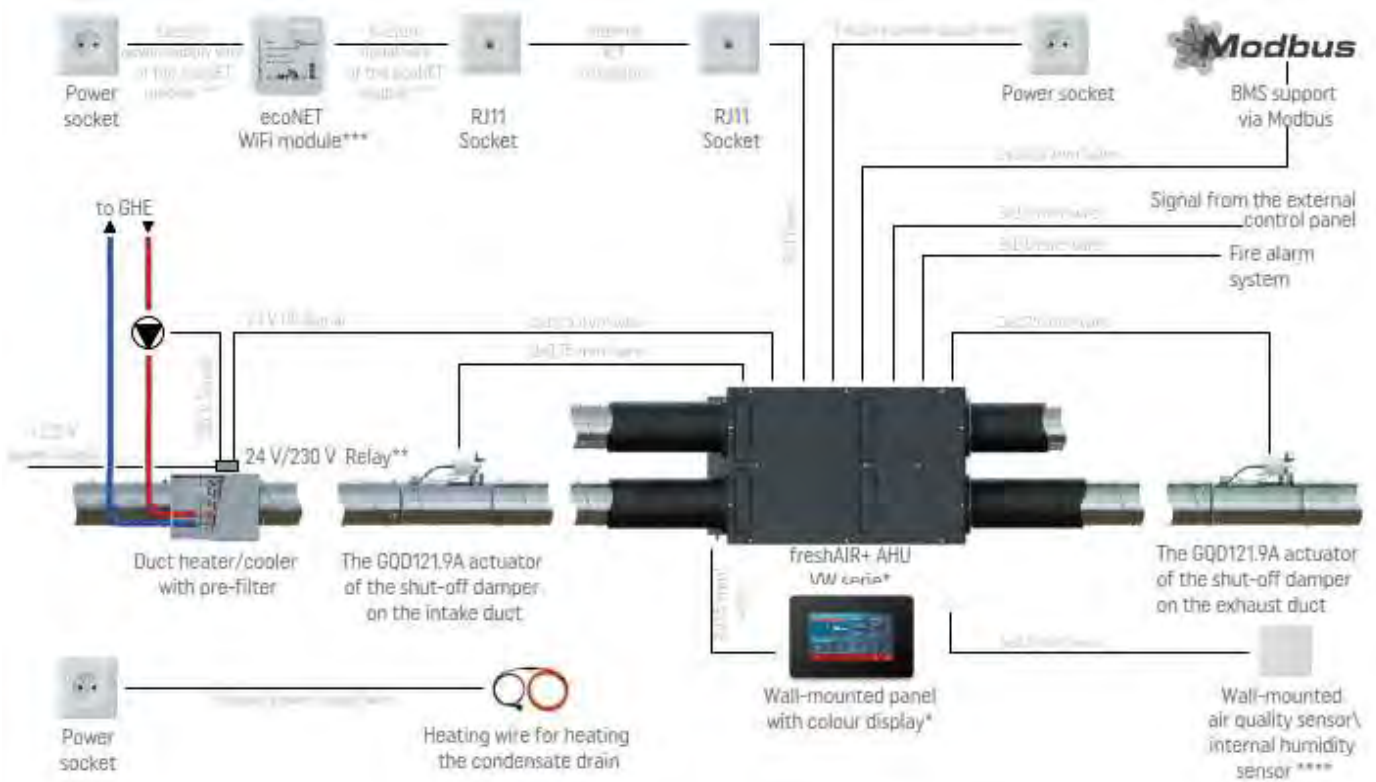

* - Standard scope of delivery for a heat recovery unit. The supply socket for the air handling unit should be made on a separate electric circuit equipped with a residual current circuit breaker of min. 16A. The maximum length of the given cables is 50 m. The humidity sensor is built into the control panel.

** - The controller controls the operation of the GHE pump through a 24 V / 230 V relay located in an electrical box located on the duct preliminary heater

7. Commissioning and acceptance of the installation

7.1. Before commissioning the installation

In order to carry out a safe and correct initial commissioning, make sure that the installation has been carried out in a correct manner, in accordance with the design, that is:

- the ventilation ducts have been properly installed and insulated,
- the ventilation valves have been opened,
- the installation has been pre-tuned.

It is also necessary to verify the correctness of the installation of the recuperator itself, including its leveling, lack of fan blockages and whether the filters are properly installed and there are no foreign bodies inside the device.

You should also confirm the correct installation of the siphon as well as the slope and patency of the condensate drainage pipes. The AHU's drip tray should be filled with water and the correct connection of the device with the condensate drain system should be checked.

It is forbidden to start the device without installed air filters.

7.2. The first run

To start the device, connect the mains plug directly to a power socket. It is forbidden to power the device via an extension cord or power distributor. Then start the device by setting the bipolar switch to the "I" position.

8. Service and maintenance works



All service and maintenance works should be performed with the AHU turned off and disconnected from the power source.

8.1. Filter replacement

For the sake of comfort and hygiene, it is recommended to replace the set of filters in a period not longer than **90 days**. Due to air pollution, variable due to local geographic conditions, building conditions and changing weather conditions, it is recommended to constantly inspect the filters and replace them depending on the real demand.

However, the condition of the filters should be checked on an ongoing basis and, if necessary, replaced more often. It is recommended to check the filters at least every **60 days**.

Filters intended for use in VS series AHUs:

- supply air pre-filter ePM10 (60%),
- supply air fine filter ePM1 (55%),
- ePM10 extract air filter (60%).

The use of filters with different dimensions, filtration classes or design other than the original ones may result in improper operation of the device. In order to ensure the proper operation of

the device and the comfort of users, it is recommended to use original filters offered by the manufacturer.

It is forbidden to start and use the device without installed air filters.

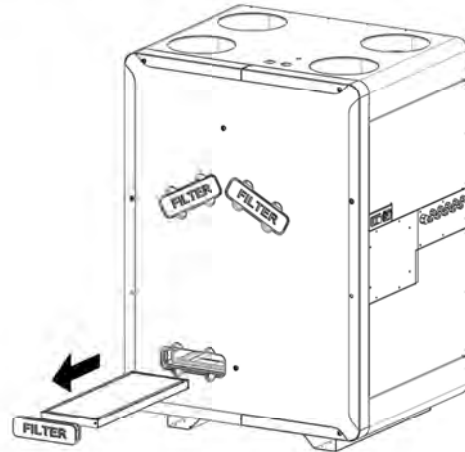

In order to replace the filter:

1. Turn off the device and disconnect it from the power supply.
2. Remove the filter cap.
3. Remove the old filter and insert a new one.
4. Apply silicone spray to the filter cap, wait 5 minutes (optional).
5. Close the filter cap.
6. Repeat steps 1-5 for each filter.
7. Connect the device to the power supply, start it.
8. Restart the filter counter in the controller.

Used filters should be disposed of in accordance with local waste management regulations.

After starting the device, reset the air filter counter in the device controller in the Installer menu: Filter settings> force the filter replacement procedure.

8.2. Removing the service cover

Maintenance work other than changing the filter requires the prior removal of the service cover. Dismantling requires the use of a size 6 Allen key.

Dismantling should begin with removing the screws securing the cover.

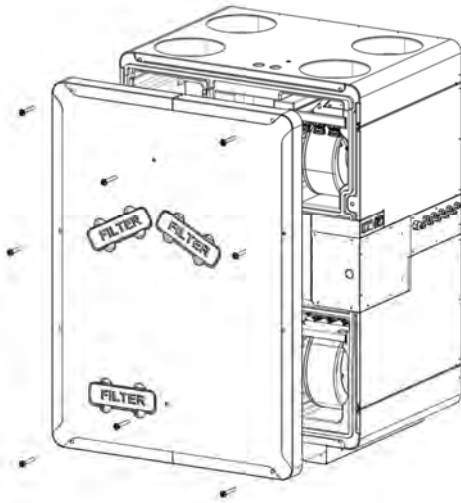

The next step is to remove the cover. Due to the use of a sealing lock, it is recommended to evenly remove the cover, starting from tilting it, holding its longer side.

After removing the service cover, the user gains access to all components located in the VS series recuperator.

Install the cover in the reverse order of removal. Make sure the cover is pressed evenly against the housing before tightening the securing screws.

8.3. Heat exchanger service

The heat exchanger should be inspected and serviced **at least once a year** by a properly trained installer or service technician. When carrying out service work, follow the principles of Occupational Health and Safety, including the use of gloves and protective clothing, which will minimize the risk of injury due to contact with sharp edges.

In order to service the heat exchanger:

1. Turn off the device and disconnect it from the power supply.
2. Remove the service cover.
3. Visually inspect the level of dirt and the condition of the heat exchanger fins - Contact the Manufacturer if there is any visible damage.
4. Clean the heat exchanger with a vacuum cleaner. Clean the exchanger from the side of each of the 4 inlets. Start purging in such a way as to cause the air to move in the direction opposite to the direction of normal operation (1. Intake, 2. Air supply, 3. Exhaust air, 4. Exhaust).



To clean the exchanger, use a vacuum cleaner attachment with soft bristles. Damage caused by improper service is not covered by the warranty.



Disassembly of the exchanger and washing it under running water is recommended by the manufacturer only in special cases - the heat exchanger is protected against dirt from the outside and dirt from the rooms by a 2-stage filtration system.

In the event of heavy dirt on the exchanger, it is recommended to disassemble it in order to clean the exchanger under running water. To do this, you need to:

1. Unscrew the 2 nuts securing the exchanger cover.
2. Dismantle the cover of the exchanger chamber.
3. Disconnect the wiring harness from the bypass and the heating mats.
4. Remove the by-pass by pulling the textile strap towards you.
5. Remove the exchanger by pulling the textile strap towards you.
6. Put the dried exchanger into the chamber
7. Install the by-pass by inserting it into the chamber, moving it to the exchanger and reconnecting the wiring harness
8. Reassemble the exchanger chamber cover and tighten the nuts in order to seal the exchanger chamber
9. Install the service cover and tighten the screws to seal the connections.
10. Connect the device to the power supply, start it.

8.4. Bypass service

The by-pass condition should be checked in case of suspicion of malfunctioning, for example, when air is blown in with very low temperature in winter. The service should be run by a trained installer or service technician.

In order to carry out a bypass service:

1. Turn off the device and disconnect it from the power supply.
2. Remove the service cover.
3. Remove the cover of the exchanger chamber.
4. Unfasten by-pass connectors located in the supply air chamber.

5. Remove the first bypass by pulling the textile strap towards you, then disassemble the exchanger in the same way and the second bypass, located at the end of the exchanger chamber.

6. The bypass connector should be connected to the service power supply. Using the power supply setting, perform the operation of closing and opening the throttle. While the actuator is in operation, the operation should be monitored and the bypass condition should be assessed on this basis. The bypass actuator operation should be audible after changing the settings on the service power supply.

7. Install the first bypass by inserting it into the exchanger chamber, then insert the exchanger and finally insert the second bypass.

8. Reconnect the bypass connectors to the unit connector.



Make sure that no foreign body has entered the bypass housing that could interfere with the operation or damage the device.

9. Reassemble the exchanger chamber cover and tighten the nuts in order to seal the exchanger chamber.

10. Install the service cover and tighten the screws to seal the connections.

11. Connect the device to the power supply, start it.



If, after completed maintenance, the bypass does not start or does not work properly, please contact the Manufacturer.

8.5. Fan service

Fans should be inspected and serviced at least once a year by an authorized installer or service technician. When carrying out service work, follow the principles of Occupational Health and Safety, including the use of gloves and protective clothing, which will minimize the risk of injury due to contact with sharp edges.

Location of fans and connectors

The fan modules used in VS series air handling units are installed on a frame accessible after removing the service hatch. The modules are also equipped with temperature sensors that allow to regulate the AHU operation. Sensors are an integral part of the fan modules.

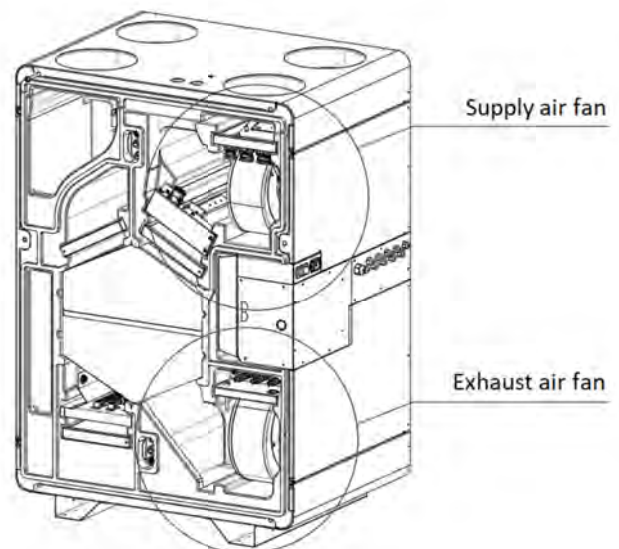

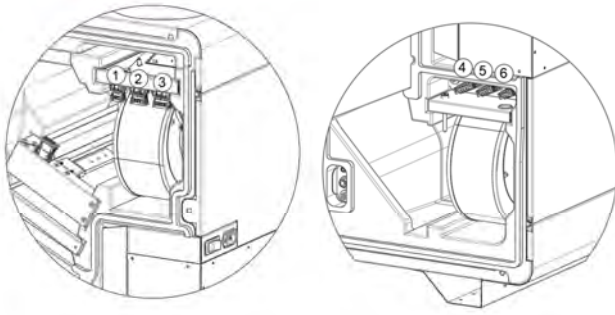

The course of service work - cleaning the fan:

1. Turn off the device and disconnect it from the power supply.
2. Remove the service cover.
3. Unclip the fan and temperature sensor connectors attached to the fans mounting frames. In order to disconnect the wires, lightly squeeze and pull the plugs of the couplings used.

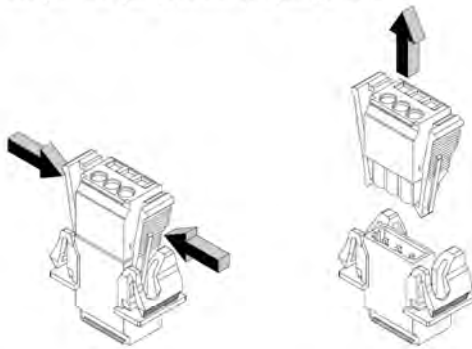

4. Carefully slide the fan module out of the device housing.

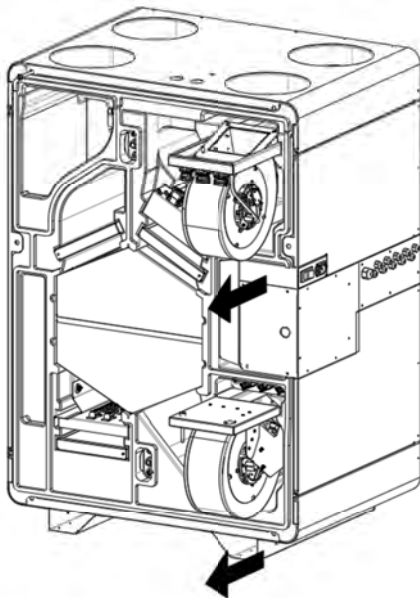

5. Place the fans on a stable, flat surface.
6. Visually inspect the wiring, impeller and housing for each fan.
7. Clean the fans, i.e. the housing and the impeller with a damp, soft cloth. A mild detergent is allowed. It is also permissible to clean the fan with a stream of compressed air.



The fan motor does not require service and any interference with its casing is the basis for voiding the warranty.



It is forbidden to immerse the fan in liquid, as well as to use pressure cleaning equipment, abrasive materials, solvents and aggressive substances.

8. Carefully slide the fan module into the housing of the device.
9. Connect the fan and temperature sensor connectors.



When connecting the fan connectors, pay attention to the markings. Connecting the control circuit to the power supply can damage the device.



Make sure that no foreign matter has entered the fan housing that could interfere with the fan's operation or lead to its damage.

10. Install the service cover and tighten the screws to seal the connections.
11. Connect the device to the power supply, start it.



If the fan does not start or does not work properly after the maintenance is completed, please contact the manufacturer.

8.6. PTC pre-heater service



During operation, the temperature of the heater elements may reach high temperatures. For this reason, before starting work, it is essential to wait until the elements cool down.

The heater should be inspected and serviced **at least once a year** by a properly trained installer or service technician. When carrying out service work, follow the principles of Occupational Health and Safety, including the use of gloves and protective clothing, which will minimize the risk of injury due to contact with hot surfaces and sharp edges.

The location of the pre-heater is shown in the figure below.

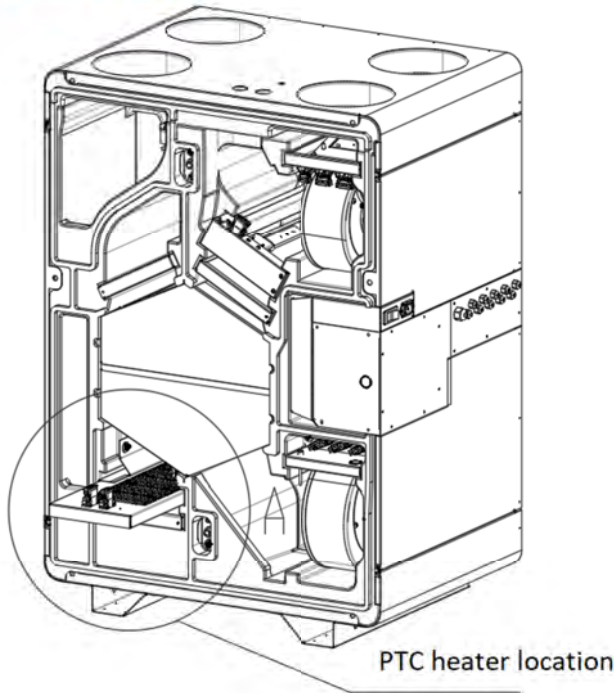

If the heater does not start up or does not work properly after the maintenance is completed, please contact the manufacturer.

8.7. Service of the air cleaning module with a UV lamp

The air purification module with a UV lamp should be inspected and serviced at least once a year by a properly trained installer or service technician. When carrying out service work, follow the principles of Occupational Health and Safety, including the use of gloves and protective clothing, which will minimize the risk of injury due to contact with sharp edges.

The course of service work - cleaning the UV module:

1. Switch off the device and disconnect it from the power supply.
2. Remove the service cover.
3. Unclip the module power connector. To disconnect the cable, gently squeeze and pull up the plug used.
4. Carefully slide the air cleaning module out of the device housing.
5. Place the module on a stable, flat surface.
6. Visually assess the condition of the wiring and mechanical connections.
7. Replace the UV lamps.



The lifetime of the UV lamps is specified by the manufacturer for 1 year from the date of commissioning the device. In order to maintain the warranty on the device, it should be replaced before the end of the assumed service life. Used UV lamps should be disposed of in accordance with local regulations.

8. Carefully slide the air cleaning module into the device housing
9. Connect the module power connector.
10. Install the service cover and tighten the screws to seal the connections.
11. Connect the device to the power supply, start it.



If, after the maintenance is completed, the module does not start or does not work properly, contact the manufacturer.

8.8. Condensate drain service and control

The condensate drain system should be inspected and serviced **at least once a year** before the heating season. This is due to the periodicity of the appearance of condensate, which occurs in the case of low outside temperatures. Works should be carried out by a properly trained installer or service technician in accordance with the principles of Occupational Health and Safety.

The course of service work - condensate drain:

1. Switch off the device and disconnect it from the power supply.
2. Remove the service cover.
3. Remove any solids that may have accumulated around the condensate drain.
4. Clean the drip tray with a damp cloth.

The connections of the heater with the AHU controller have been made using dedicated connectors: two-pole power connectors and four-pole temperature sensor connectors.

The course of service work - cleaning the PTC pre-heater:

1. Switch off the device and disconnect it from the power supply.
2. Remove the service cover.
3. Wait until the heating elements cool down, then disconnect the power and temperature sensor connectors. To disconnect the wires, squeeze the plugs used slightly and pull them upwards.
4. Carefully slide the heater module out of the appliance housing.
5. Place the fuser unit on a stable, flat surface.
6. Visually inspect the condition of the wiring and mechanical connections between the modules and the frame of the heater.
7. The heater, i.e. the frame and the heating modules, should be cleaned with a damp, soft cloth. It is allowed to use a mild detergent and clean the heater with a stream of compressed air.



The resistance elements do not require service and any interference with their housing is the basis for voiding the warranty.



It is forbidden to immerse the heater in liquid, as well as to use pressure cleaning equipment, abrasive materials, as well as solvents and aggressive substances.

8. Carefully slide the heater module into the appliance housing
9. Connect the power and temperature sensor connectors.
10. Install the service cover and tighten the screws to seal the connections.
11. Connect the device to the power supply, start it.

5. Assess the condition of connection of the AHU with the condensate drainage system.
6. Check the drainage of the condensate drainage system by pouring approximately 0.5 liter of water into the AHU's drip tray. If the water cannot drain away easily, the condensate drain pipes must be dismantled and cleaned.

At the same time, the tightness of the connections should be checked.

If a wet siphon was used in the installation, the presence of water that could evaporate during the summer period should also be periodically verified. In the event of a lack of water, the siphon should be filled to prevent odors from entering the ventilation system.

1. Install the service cover
2. Connect the device to the power supply, start it.

8.9. Service and maintenance of the controller

The condition of the electrical connections and the controller circuit board should be inspected at least once a year. Work should be carried out by a properly trained installer or service technician in accordance with the principles of Occupational Health and

Safety. It is recommended to use gloves and protective clothing to minimize the risk of injury due to contact with sharp edges.

The course of service work - maintenance of the control board and checking the electrical connections:

1. Switch off the device and disconnect it from the power supply.
2. Disassemble the controller cover by unscrewing the screw located in the upper part of the controller housing.
3. Visually assess the condition of the PCB.
4. If solid contamination is detected, it is recommended to clean the plate with a stream of compressed air.
5. Check the condition of the electrical connections by gently moving the wires.
6. In the event of damage being found, contact the manufacturer.
7. Assess the condition of other components located in the controller housing, including the condition of electrical and mechanical connections.
8. Install the controller cover
9. Connect the device to the power supply, start it.

If the device does not start up or does not work properly after the maintenance is completed, please contact the manufacturer.

9. Operation of the controller for the installer



The following sample diagrams do not replace the design of the ventilation system. They are for illustrative purposes only!

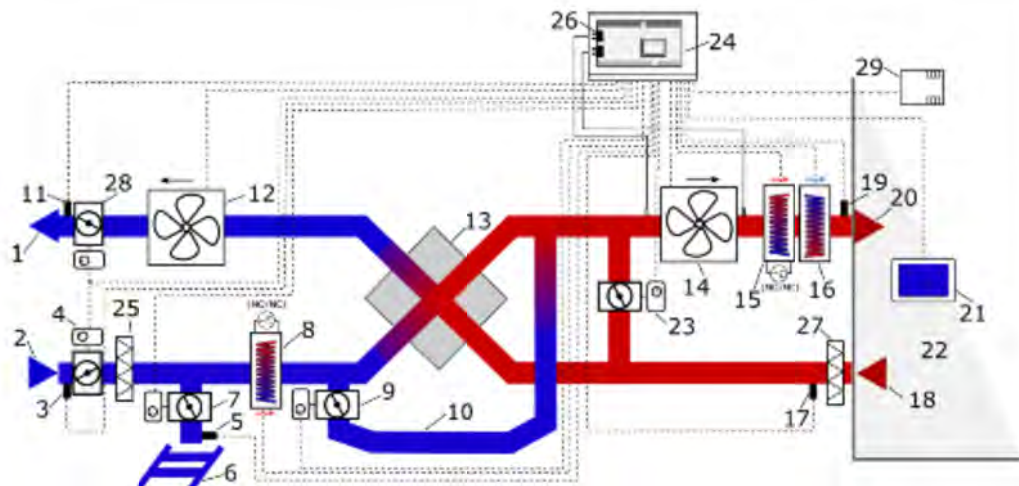

Ventilation scheme with a cross-flow (or counter-flow) exchanger and a secondary freon or water cooler, and a primary and secondary electric heater.

Description of diagrams: 1 – exhaust, 2 – intake, 3 – intake temperature sensor (outdoor temp.), 4 – intake throttle actuator, 5 – GHE temp. sensor, 6 – GHE, 7 – GHE throttle actuator, 8 – primary electric or water heater with thermostat, 9 – bypass throttle actuator, 10 – bypass, 11 – exhaust temp. sensor, 12 – exhaust fan, 13 – cross-flow exchanger (countercurrent or rotary) 14 – air supply fan, 15 – secondary electric or water heater with thermostat, 16 – freon or water secondary cooler, 17 – extraction temp. sensor (from the room), 18 – extraction, 19 – air supply temp. sensor, 20 – air supply, 21 – control panel, 22 – ventilated room, 23 – mixing chamber throttle actuator, 24 – controller module, 25 – fresh air filter, 26 – differential pressure sensors, 27 – exhaust air filter, 28 – exhaust throttle actuator, 29 – air quality or humidity sensor.

The following sample schemes automation does not replace the design of ventilation systems. It is used only as an example!

Brief description of the operation with cross-flow exchanger.

In the moment of turning on the controller, throttles of air supply and extraction are opened by actuators, next the air supply and exhaust fans start to work. Depending on the demand for cooling or heating and fulfilling determined temperature and time requirements, the controller automatically opens or closes the bypass throttle and/or mixing chamber, starts up the freon cooler or secondary heater (electric or water) or starts fan convector and controls it according to actual demand. Anti-freezing protection is realized, depending on recuperation central configuration, by opening bypass throttle, by changing fans adjustment, by heating up the outdoor air using primary heater.

9.1. Technical data

The controller power supply	230 V~, 50 Hz
Current consumption	0,04 A ¹
Max. rated current	6 (6) A
Ambient temperature	0...40°C
Storage temperature	-25...50°C
Relative humidity	5...85%, without steam condensation
Temperature measurement range of NTC 10K sensors/accuracy	-40...+60°C / ±2°C
Measurement range of differential pressure sensor/accuracy of internal differential pressure sensor	±500 Pa / ±3% of measuring
Screw terminals, mains	Cross-section: 0,5...2,5 mm ² , tighten 0,55 Nm, spacing 7 mm
Screw terminals, signals	Cross-section: 0,25...1,5 mm ² , tighten 0,23 Nm, spacing 7 mm
Display ecoTOUCH	Color, graphical 480x272 pix, with touch panel
Display simTOUCH2	Graphical: 128x64 piks.
Module dimensions	200x104x50 mm (including 9 mm spacers)
Dimensions of panel ecoTOUCH T4_RT	148x97x23 mm
Dimensions of panel simTOUCH2	126x66x17 mm
Standards	PN-EN 60730-2-9 PN-EN 60730-1
Software class	A, wg. PN-EN 60730-1
Protection class	Suitable to build-into class 1 devices

Pollution degree	2 nd degree, acc to PN-EN 60730-1
------------------	--

¹ It is the current consumed by the regulator itself. The total power consumption depends on the devices connected to the regulator

9.2. Operating conditions

The controller cannot be exposed directly to the weather conditions (rain, sunlight) and vibrations stronger than those during the transport. Do not use the controller under steam condensation conditions, protect from consumption depends on devices connected to the controller. Storage and transport temperature should not exceed the range of -25...+50°C. Install in a dry place.

9.3. The controller installation

The controller can be installed only by the ventilation system manufacturer, according to applied norms and regulations and instructions provided in controller documentation. The manufacturer bears no responsibility for damages caused by failure to comply with applied regulations or following this manual.

9.4. Mounting of control panel

The control panel is designed for mounting on the wall, inside the room. Cannot be used under steam condensation conditions, protect against water. The control panel should be mounted at a height allowing comfortable operation, typically 1.5 m above the floor.

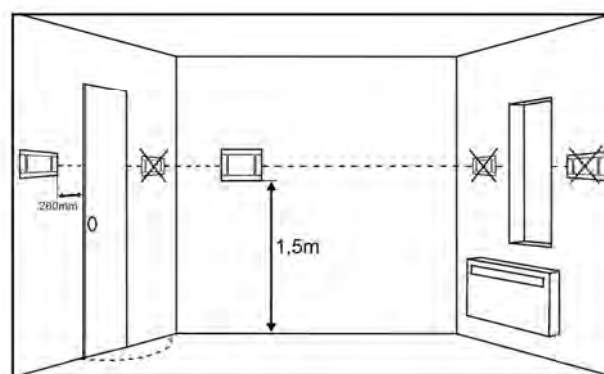

To reduce measurement disturbances avoid locations exposed to strong sunlight, with poor air circulation, near heating equipment, and directly at the door and windows (typically 0.2 m from the edge of the door).



The control panel should be installed by a trained installer.



When selecting the cable connecting the panel with the controller, the rule should be applied that the resistance of one core in the cable should not exceed 8 Ω and the total length of the cable should not exceed 100 m. As the cable length increases, its cross-section should be increased.

Exemplary cable types used to connect panel with the controller and their approved lengths:

- cable YTLYp 4x0,12 mm² (with resistance 155 Ω/km), with max. length up to 50 m,
- cable LiYY 4x0,25 mm² (with resistance 76 Ω/km), with max. length up to 100 m.

EcoTOUCH T4_RT panel:

Installation of the control panel should be in accordance with the following guidelines. Detach the mounting frame (1) from the control panel housing (2). The frame is attached to the panel housing with clips. Can use a flat screwdriver to detach the mounting frame.

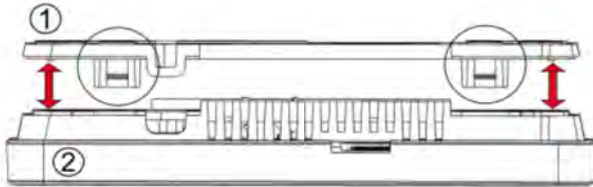

Use a sharp tool to cut out the cover (3) in the four places.

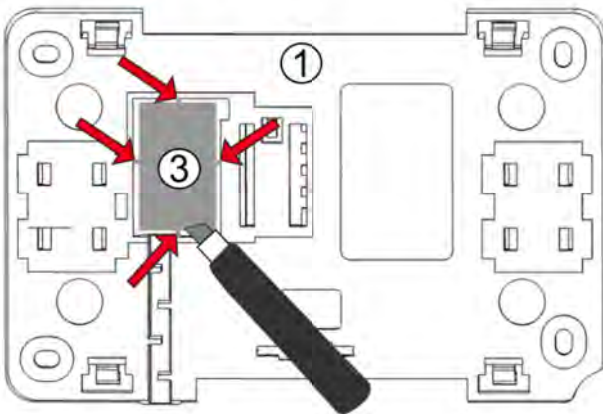

Connect the wires of the transmission cable connecting the panel with the controller to the screw terminal (4), in accordance with the description (5). The cable connecting the panel with the controller may be recessed in the wall or may run along its surface - in this case, the cable should be additionally placed in the cable channel (6) of the mounting frame. The cable connecting the panel with the regulator cannot be routed together with the building's electrical network cables. The cable should not run in the vicinity of devices emitting strong electromagnetic fields.

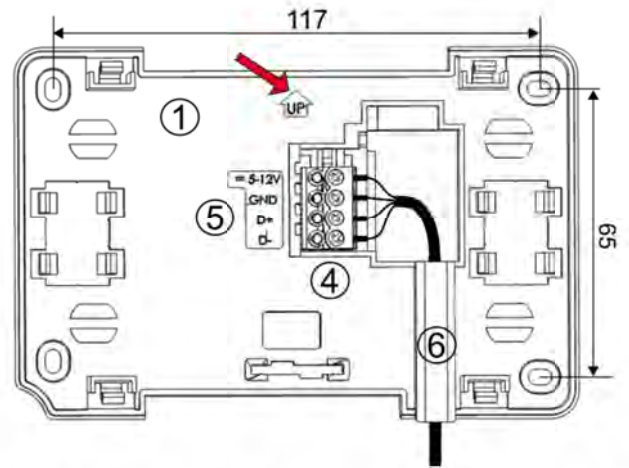

Drill holes in the wall and use screws (max. Ø 3 mm) to fix the mounting frame in a selected place on the wall, keeping the appropriate position (UP). The spacing of openings can be determined by placing the mounting frame against the wall. Then attach the panel to the mounting frame with the use of latches.

Panel simTOUCH2:

A hole in the housing should be made in accordance with the drawing below.

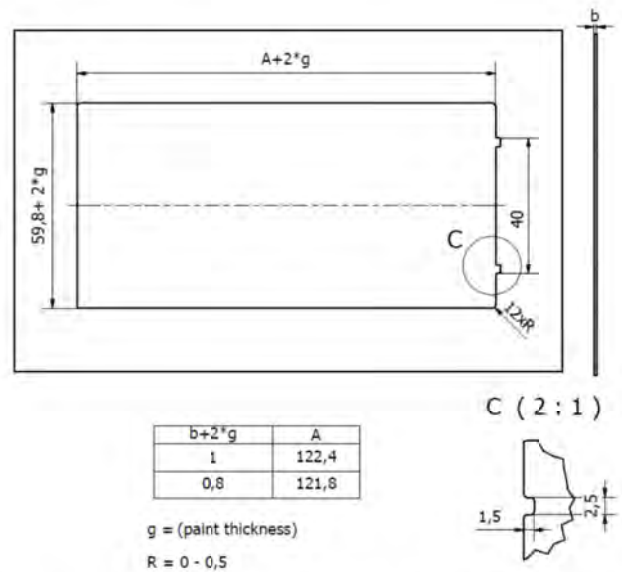

Then connect the transmission cable to the RJ socket of the panel.

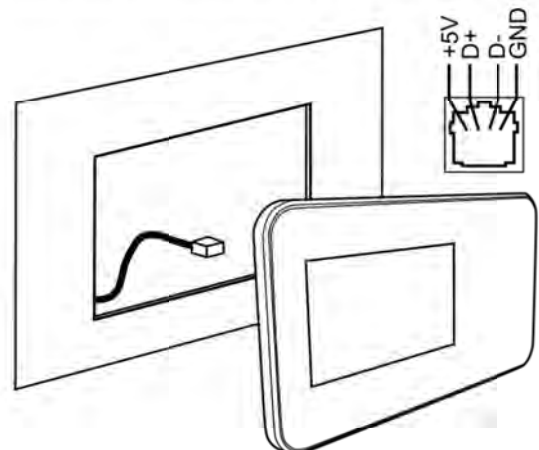



The maximum length of the transmission cable should be 5 m with a cross-section of 0.5 mm²

9.5. Main module installation

The controller's module must be developed. The development must provide the protection level corresponding to the environmental conditions, under which the controller will be used and prevent users access to the controller terminals. The IP protection level of undeveloped module is IP00. The dangerous voltage part is accessible here.



Keep safe spacing between module terminals and conducting casing elements, min. 10 mm.

An example of a metal enclosing of the module is shown in the figure below. The minimum required spacing is given.

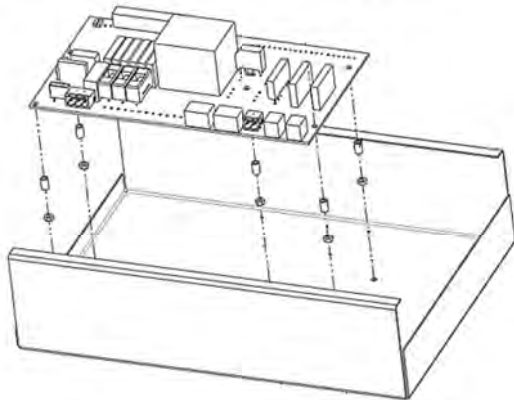

Assembly dimensions of the module are shown in the further part of the manual.

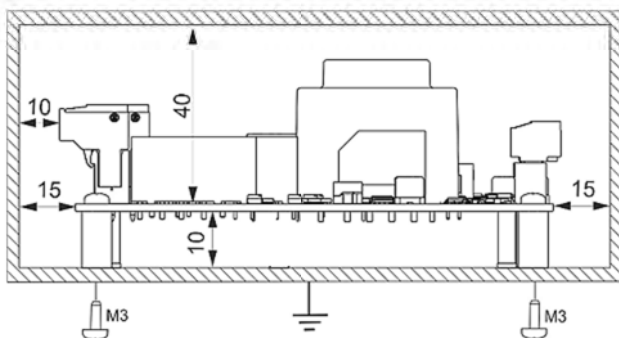

The development must provide protection for cable terminals against ripping, loosening or tension occurrence. Metal enclosing should be grounded

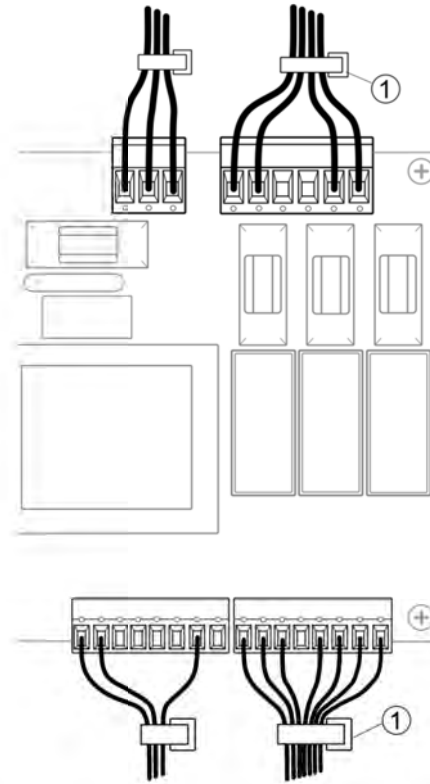

Cables connected to the plate should be fastened (1) so that accidental falling out of one of the wires could not cause a hazard.

9.6. Cleaning and maintenance procedures

The outer surface and maintenance of the control panel screen.



The device should be cleaned with a soft, dry cloth.



It is not allowed to clean the device with a flammable substance (e.g. benzene or any kind of solvent) or a wet cloth. This can cause device malfunction.



It is not allowed to scratch the screen with fingernails or sharp objects. It can lead to device damage.



It is not allowed to clean the device by spraying water or other liquids on it. If the liquid gets inside the device it can cause fire, electrocution or damage to the device.



It is not allowed to use damaged: power supply cable, plug or loose electric outlet. Ignoring above recommendations may lead to electrocution or fire outbreak.

9.7. Electrical connection

The controller is designed to be supplied by the 230 VAC voltage, 50 Hz – connected to L, N terminals.

The electrical mains should be:

- three-wire (with the protective PE wire),
- in accordance with current regulations.



After turning off the controller, dangerous voltage can still occur on the terminals. Before any assembly works, power supply must be utterly disconnected, make sure if there is no dangerous voltage on controller terminals.



Connecting electrical mains to digital and analog transmission inputs will damage the controller and may cause electrocution threat.

Connect the PE protective wire with module PE input and housing terminal and protective cables of connected devices.



Connection of all peripheral devices has to be done by the installer in accordance with current regulations. Precautions to prevent electrocution should be applied. The controller has to be

equipped with a set of plugs inserted into connectors powering devices with 230 VAC voltage.

The controller has been equipped with screw terminals insert able into sockets, adjusted to use wire with collets. Tips of connection cables, especially mains voltage cables should be secured from splitting by e. g. insulated clamp sleeves. Use wire dimensions and tightening torques provided in technical data.

9.8. Electrical diagram

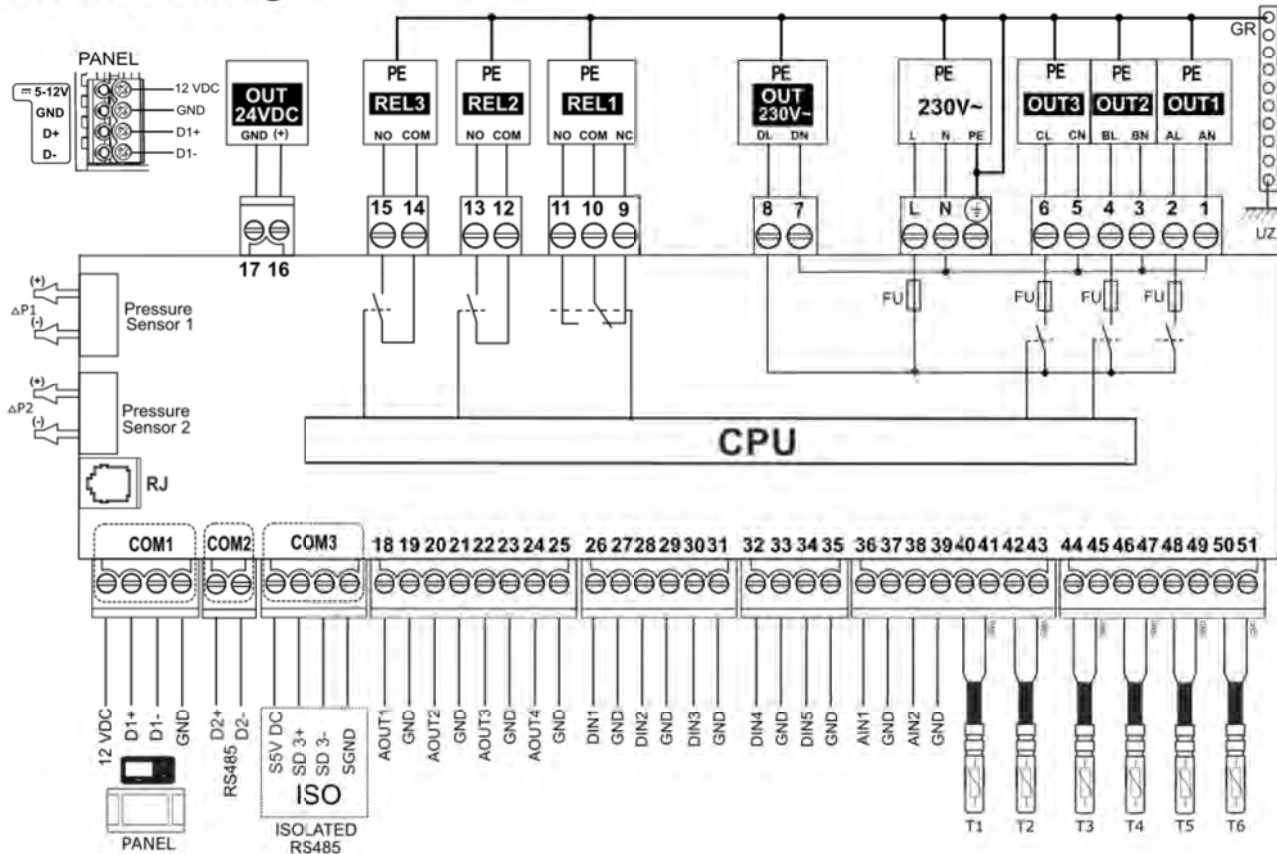

The controller allows any configuration of outputs depending on the needs of used ventilation system. Under the scheme is described sample outputs configuration.

Analog outputs (NTC 10K):

- T1** – temp. sensor behind exchanger (optional)
- T2** – supply temp. sensor (required);
- T3** – extraction temp. sensor (required);

- T4** – intake temp. sensor (required);
- T5** – GHE temp. sensor (required);
- T6** – exhaust temp. sensor (required);

Analog inputs (0-10 V):

- AIN1** – analog humidity sensor;
- AIN2** – empty;

Digital inputs (digital):

- DIN1 (IN1)** – fans adjustment change – hood mode, stage 1 (Normally open);
- DIN2 (IN2)** – fans adjustment change – hood mode, stage 2 (Normally open);
- DIN3** – signal input from FAS (Normally closed);
- DIN4** – signal input from alarm system (Normally open);
- DIN5** – heaters thermostats (Normally closed);

Analog outputs (0 – 10 V):

- AOUT1** – air supply fan;
- AOUT2** – exhaust fan;

Analog outputs (0 – 10 V or PWM*):

- AOUT3** – secondary heater;
- AOUT4** – water or freon cooler;

Relay outputs 230 VAC:

- OUT1** - air supply fan;
- OUT2** – exhaust fan;
- OUT3** – GHE throttle actuator;

Relay outputs (potential free):

- REL1** – primary heater;
- REL2** – secondary heater;
- REL3** – bypass throttle actuator;

Transmission channels:

- COM1** – control panel (supply power 12 VDC);
 - COM2** – transmission socket for additional expansion modules (RS485);
 - COM3 (ISOLATED)** – isolated RS485 port and SGDN (external communication port);
 - ΔP1, ΔP2** – differential pressure sensors ecoPRESS IN1 (optional).
 - RH1, RH2** – eV-Ex01_v1.0 adapter sockets for connecting a humidity sensor (SRHT IN1 type);
 - CPU** – control;
 - LN** – mains power 230 VAC;
 - PE** – peripheral devices grounding;
 - FU** – mains fuse;
 - GR** – grounding;
- * available depending on board version.

9.9. Temperature sensor connection and installation



Sensors necessary to run the controller and the correct operation are the air supply, extraction, exhaust and intake temp. sensors.

extended by a cable with cross-sectional area min. 0,5 mm², a total cable length max. 15 m. Make a hole in the ventilation duct in the place designated for temperature measurement, put on the rubber sleeve (1) and install the sensor. The sensor should be attached to the duct using tape to ventilation insulation (2), as shown in the figure below.

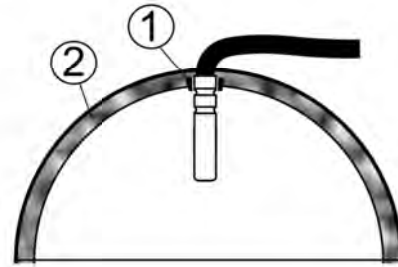

Sensors must be properly mounted and protected against loosening from the ventilation ducts according to installation manufacturer recommendations.

It is not allowed to flood sensors with water/oil. Sensor cables should be isolated from mains lines and heat sources to avoid false temperature readings. Minimum spacing between sensor cables should be min. 400 mm. The sensors must be connected to the controller according to the electrical scheme.

9.10. Temperature sensors testing

Sensors are tested by measuring resistance in given temperature. Temperatures with corresponding resistance values are provided in table below.

NTC 10K	
Ambient temp. °C	Nom. Ω
0	33620
10	20174
20	12535
30	8037
40	5301
50	3588
60	2486
70	1759
80	1270
90	933
100	697
110	529
120	407

9.11. Connecting differential pressure sensors

The module operates only with ecoPRESS-IN1 differential pressure sensors. Using different sensor types is forbidden. Sensors should be placed on the module board at marked place (Pressure Sensor 1 and Pressure Sensor 2) by inserting sensor pins into module sockets, in accordance with figure below.

Use only the following temperature sensors of NTC10K type. Using different sensor types is forbidden. Sensors cables can be

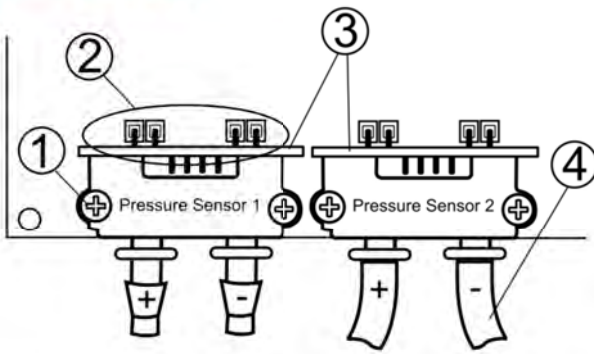

Mounting the ecoPRESS-IN1 pressure sensors: 1 - M2.5 x 25 screw + nut, 2 - adapter connector pins, 3 - sensor, 4 - Ø4 mm (inner diameter) pressure pipe, (+) - pressure before laminar flow limiter, (-) – pressure behind laminar flow limiter.

Pressure sensors must be firmly mounted to the module board with screws, otherwise measurement errors might occur due to mechanical tensions. The pressure tubes connected to the sensor's connectors should be inserted into the ventilation duct with a laminar flow limiter, maintaining proper connection of pressure values before (+) and after (-) this limiter. The pressure tubes must be properly sealed and secured against being pulling out.

9.12. Connecting differential pressure sensors

The ecoPRESS EX1 external transducer should be connected to the controller COM2 port or to the AIN port, according to the electric scheme. The sensor can be powered from the regulator socket or an external 12...24 VDC or 12...15 VAC power supply.

9.13. Connecting air parameters threshold sensor

Air parameters threshold sensor (humidity or CO2) should be installed according to the sensor's manufacturer guidelines. Connection cables can be extended, unless specified otherwise in sensor documentation. Its length must be selected accordingly to the manufacturer's guidelines. During installation works cables must be implicitly secured against pulling out.

9.14. Connecting the internet module

The ecoNET300 internet module should be connected and configured according to manufacturer's recommendations.

9.15. Air filters



Before the first operation of the ventilation system, check the condition of the filters. The ventilation central cannot work with dirty filters or with no filters installed!

The mechanism monitoring filters dirtying should be selected through cooperation between the installer's and manufacturer's service. The controller manufacturer offers three dirt detection mechanisms: based on time mechanism, based on readings from external pressure switches and based on reading from differential pressure transducers. Depending on system manufacturer settings, installer's service can have an access to dirt detection mechanisms, filter classes parameters, defining dirtying conditions and starting alarm mode from the level of dedicated menu. Connect and configure pressure switches and/or differential pressure transducers according to recommendations of its manufacturers and ventilation system manufacturer.



The system should not run for long periods of time with dirty filters, as this could damage the fans motors.



Ask the manufacturer or qualified installer for replacement of the filters.



It is recommended to use a throttle with a return spring on the intake side, which allows cutting off the airflow when the controller is turned off.

9.16. Modbus communication

9.16.1. Modbus RTU protocol

The controller has integrated software module allowing communication using Modbus RTU protocol. The protocol enables read from register / group of registers containing current parameters values and a record of values to chosen parameters. The controller supports three Modbus requests: read 0x03, single register modification request 0x06 and group of registers modification request 0x10. Communication is done on isolated port of controller (COM3 ISO), which is slave type port.



Communication is performed in RS485 standard. To provide transmission reliability it is obligatory to connect D+ and D- signal cables with proper ports of imperative (master) device and controller (slave).

9.16.2. Communication settings

Ustawienia komunikacji Modbus RTU znajdują się w menu:

Menu instalatora → Ustawienia Modbus

Modbus RTU communication settings are in menu:

Service menu → Modbus settings

To establish proper communication the following parameters must be set:

- Modbus address – controller's address on Modbus bus.
- Transmission speed – requested Modbus transmission speed; available settings: 9600, 19200 or 115200.
- Stop bytes – number of bytes ending Modbus frame; available settings: 1 byte or 2 byte.
- Parity – ability to control errors by comparing frame sum to value of additional parity byte; available settings: none (parity control not applied), even (to control correctness a parity byte is used), odd (to control correctness odd parity byte is used).



Parameters: Transmission speed, Stop bytes and Parity must be configured identically in all devices on the line. Otherwise connection will not be established.

- Modbus activation – permission for communication using Modbus protocol; setting parameter to No will result in blocking controller.

- *Parameters edit – permission to edit parameters using Modbus; if parameter is set to No modification requests 0x06 and 0x10 will be blocked.*

- *Ventilation system control – permission to control with Modbus; if parameter is set to No controlling the controller from Modbus level will be disabled.*

9.16.3. Read request 0x03

Modbus communication protocol allows reading register (or group of registers) containing current parameters values. Read request frame includes (looking at the beginning of the frame):

- address of requested device (1 byte)
- requests (1 byte, in case of read request – 0x03)
- number of first read register (2 bytes)
- numbers of read registers (2 bytes)
- CRC (2 bytes)

Request sample:

01 03 00 04 00 02 85 CA

According to protocol specification, above request defines read of 2 (00 02) data registers counting from register 4 (00 04) from device with address 1 (01) using read request 0x03 (03).

Exemplary answer:

01 03 04 00 03 00 01 CB F3

According to protocol specification, above frame informs, that two following registers (4 bytes together – 04) of the device with address 1 (01) have values: 3 (00 03) and 1 (00 01), and to read these values read request was used (03).

9.16.4. Modification request 0x06

Modbus communication protocol allows modification value 1 of register containing current value of parameter. Request frame includes (looking at the beginning of the frame):

- address of requested device (1 byte)
- requests (1 byte, in case of modification request – 0x06)
- number of modified register (2 bytes)
- value to set (2 bytes)
- CRC (2 bytes).

Request sample:

01 06 00 04 00 03 88 0A

According to protocol specification, above request defines modification of data register value number 4 (00 04) in the device with address (01) to value 3 (00 03) using modification request (06).

Answer to the modification request depends on that, if value modification operation will be successful. If modification is successful a compatibility frame will be returned. If modification is unsuccessful an error frame will be returned. Compatibility frame is identical to the previously sent modification request frame. Error frame includes (looking at the beginning of the frame):

- address of requested device (1 byte)
- request echoes + error marker (1 byte, in case of read request – 0x86)
- error code
- CRC (2 bytes).

Exemplary answer signaling modification error:

01 86 03 02 61

According to protocol specification, above frame informs, that in the device with address 1 (01) value modification of single parameter (86) was unsuccessful due to forbidden data value (03).

9.16.5. Modification request 0x10

Modbus communication protocol allows value modification of many registers containing current values of parameters. Request frame includes (looking at the beginning of the frame):

- address of requested device (1 byte)
- requests (1 byte, in case of modification request – 0x10)
- number of the first modified register (2 bytes)
- number of modified registers (2 bytes)
- number of modified bytes (2x number of modified registers)
- value to set (2 bytes) in register 1, 2, ...
- CRC (2 bytes).

Request sample:

01 10 00 27 00 02 04 00 15 00 16 20 5B

According to protocol specification, above request defines modification of data register value counting from register number 39 (00 27) in the device with address 1 using frame 0x10 (10). Values 2 (00 02) of registers are to be modified, together 4 bytes (04). They are to be set to the following values: 21 (15) and 22 (16). Answer to the modification request depends on that, if value modification operation will be successful. If modification is successful a compatibility frame will be returned. If modification is unsuccessful an error frame will be returned.

Compatibility frame is an echo of modification request frame, it differs only with no information regarding value to be set.

Error frame includes (looking at the beginning of the frame):

- address of requested device (1 byte)
- request echoes + error marker (1 byte, in case of read request – 0x90)
- error code
- CRC

Exemplary answer signaling modification error:

01 90 03 0C 01

According to protocol specification, above frame informs, that in the device with address 1 (01) the modification of multiple parameters (90) was unsuccessful due to forbidden data value (03).

9.16.6. Modbus table

The following table includes full list of controller Modbus parameters. This table is applied to S003.08 programs and newer.

BMS Index	Modbus address	Variable name	Description	Signal type	Min.	Max. value	Default	Variable type	Comments
1	0	Program version	Software version	O	0	0xFFFF	0	hex	Format: SXXX.YYY XXX – older byte, YYY – younger byte
2	1	Serial NO	Recuperator serial number	O	1	65535	0	integer	
3	2	STATUS_OK	Operation status	O	0	1	1	integer	
4	3	AWARIA	Failure status	O	0	1	0	integer	
5	4	WORK_MODE	Controller operation mode	I/O	0	6	3	integer	0 – Off, 1 – Postój, 3 – User1, 4 – User2, 5 – User3, 6 – User4
6	5	Tmain	Leading sensor	O	0	2	0	integer	0 – exhaust sensor, 1 – air supply sensor, 2 – panel sensor
7	6	Tsup	Air supply temperature (T2)	O	-40.0	60.0	0.0	integer	999 – sensor failure
8	7	Texh	Extraction temperature (T3)	O	-40.0	60.0	0.0	integer	999 – sensor failure
9	8	Tinl	Intake/outside temperature (T4)	O	-40.0	60.0	0.0	integer	999 – sensor failure
10	9	Tout	Exhaust temperature (B4)	O	-40.0	60.0	0.0	integer	999 – sensor failure
11	10	Trec	GHE temperature (T5)	O	-40.0	60.0	0.0	integer	999 – sensor failure
12	11	Theat	Temperature behind secondary heater (T1)	O	-40.0	60.0	0.0	integer	999 – sensor failure
13	12	Tpanel	Main panel temperature	O	-40.0	60.0	0.0	integer	999 – sensor failure
14	13	Q1-limit	Air quality sensor (Q1- 0/1)	O	0	1	0	integer	0 – open contact 1 – closed contact
15	14	-	-	-	-	-	-	-	
16	15	TR1	Primary heater thermostat (N1)	O	0	1	0	integer	0 – open contact 1 – closed contact
17	16	TR2	Secondary heater thermostat (N2)	O	0	1	0	integer	0 – open contact 1 – closed contact
18	17	BYPASS	Bypass actuator status	O	0	1	0	integer	0 - throttle ON, 1 - throttle OFF
19	18	FAS	External FAS signal	O	0	1	1	integer	0 – FAS, 1 – no FAS
20	19	IN1	External signal IN1	O	0	1	0	integer	0 – inactive, 1 – active
21	20	IN2	External signal IN2	O	0	1	0	integer	0 – inactive, 1 – active
22	21	ECO	External signal ECO (alarm central)	O	0	1	0	integer	0 – inactive, 1 – active
23	22	N1	Primary heater (N1)	O	0	1	0	integer	0 – inactive, 1 – active
24	23	N2	Secondary heater (N2)	O	0	1	0	integer	0 – inactive, 1 – active
25	24	N2 control	Secondary heater adjustment (N2)	O	0	100	0	integer	Adjustment in %
26	25	Y1 control	Cooler adjustment (CH1)	O	0	100	0	integer	Adjustment in %
27	26	GWC	Ground heat exchanger actuator	O	0	1	0	integer	0 – inactive, 1 – active
28	27	SBP1	Exchanger bypass actuator – air supply (SBP1)	O	0	100	0	integer	Adjustment in %
29	28	SM1	Mixing chamber actuator (SM1)	O	0	100	0	integer	Adjustment in %
30	29	Clean	CLEAN	O	0	1	0	integer	0 – inactive,

			EXCHANGER mode						1 – active
31	30	Clean_M ANUAL	Manual exchanger cleaning	I/O	0	1	0	integer	0 – turn off, 1 – turn on
32	31	Mode_M ANUAL	Manual control mode	O	0	1	0	integer	0 – inactive, 1 – active
33	32	Mode_W INDOW	OPEN WINDOWS mode	I/O	0	1	0	integer	0 – inactive, 1 – active
34	33	Mode_O UT	OUT mode	I/O	0	1	0	integer	0 – inactive, 1 – active
35	34	Mode_P ARTY	PARTY mode	I/O	0	1	0	integer	0 – inactive, 1 – active
36	35	Mode_O VERPRE S	OVERPRESSURE mode (fireplace)	I/O	0	1	0	integer	0 – inactive, 1 – active
37	36	OVERPR ESS_valu e	Overpressure value	I/O	-100	100	-20	integer	Adjustment in %
38	37	SCHE DULER	Operation according to schedule	I/O	0	1	0	integer	0 – off, 1 – on
39	38	-	-	-	-	-	-	integer	
40	39	Temp_U SER1	Preset temperature in USER 1 mode	I/O	8	30	20	integer	Unit: °C
41	40	Temp_U SER2	Preset temperature in USER 2 mode	I/O	8	30	20	integer	Unit: °C
42	41	Temp_U SER3	Preset temperature in USER 3 mode	I/O	8	30	20	integer	Unit: °C
43	42	Temp_U SER4	Preset temperature in USER 4 mode	I/O	8	30	20	integer	Unit: °C
44	43	W1	Air supply fan, current adjustment (W1)	O	0	100	50	integer	Adjustment in %
45	44	W2	Extraction fan, current adjustment (W2)	O	0	100	50	integer	Adjustment in %
46	45	W1_EN	Air supply fan operation permission (W1)	O	0	1	1	integer	0 – inactive, 1 – active
47	46	W2_EN	Extraction fan operation permission (W2)	O	0	1	1	integer	0 – inactive, 1 – active
48	47	-	-	-	-	-	-	-	
49	48	Speed_W 1_USER 1	Speed of W1 in USER 1 mode	I/O	dyn. (25)	dyn. (100)	50	integer	Adjustment in %
50	49	Speed_W 1_USER 2	Speed of W2 in USER 1 mode	I/O	dyn. (25)	dyn. (100)	50	integer	Adjustment in %
51	50	Speed_W 1_USER 3	Speed of W3 in USER 1 mode	I/O	dyn. (25)	dyn. (100)	50	integer	Adjustment in %
52	51	Speed_W 1_USER 4	Speed of W4 in USER 1 mode	I/O	dyn. (25)	dyn. (100)	50	integer	Adjustment in %
53	52	Speed_W 1_ECO	Speed of W1 in ECO mode	I/O	dyn. (25)	dyn. (100)	50	integer	Adjustment in %
54	53	-	-	-	-	-	-	-	
55	54	Speed_W 2_USER 1	Speed of W2 in USER 1 mode	I/O	dyn. (25)	dyn. (100)	50	integer	Adjustment in %
56	55	Speed_W 2_USER 2	Speed of W2 in USER 2 mode	I/O	dyn. (25)	dyn. (100)	50	integer	Adjustment in %
57	56	Speed_W 2_USER 3	Speed of W2 in USER 3 mode	I/O	dyn. (25)	dyn. (100)	50	integer	Adjustment in %
58	57	Speed_W 2_USER 4	Speed of W2 in USER 4 mode	I/O	dyn. (25)	dyn. (100)	50	integer	Adjustment in %
59	58	Speed_W 2_ECO	Speed of W2 in ECO mode	I/O	dyn. (25)	dyn. (100)	50	integer	Adjustment in %
60	59	-	-	-	-	-	-	-	
61	60	DATE_d ay	Day	I/O	1	31	1	integer	
62	61	DATE_m onth	Month	I/O	1	12	1	integer	
63	62	DATE_y	Year	I/O	15	99	16	integer	

GLOBAL									
		ear							
64	63	TIME_hour	Hour	I/O	0	23	1	integer	
65	64	TIME_minutes	Minute	I/O	0	59	1	integer	
66	65	Stop_time_ECO	Periodic pause time in ECO mode	I/O	1	24	1	integer	Unit: hours
67	66	Work_time_ECO	Airing time in ECO mode	I/O	0	100	10	integer	Units: minutes
68	67	Filter_time_remaining	Time remaining to replace filters	O	0	999	1500	integer	Units: day
69	68	Service_time_remaining	Time remaining to general inspection	O	0	999	90	integer	Units: day
70	69	GWC_Enabled	GHE operation permission	I/O	0	2	1	integer	0-closed, 1-auto, 2 - open
71	70	GWC_Winter	GHE turn on upper threshold – winter	I/O	5	20	8	integer	Unit: °C
72	71	GWC_Summer	GHE turn on lower threshold – summer	I/O	10	30	18	integer	Unit: °C
73	72	SM1_Enabled	Mixing chamber activation (SM1)	I/O	0	1	0	integer	0 – inactive, 1 – active
74	73	SM1_Limit	Opening limit of mixing chamber actuator (SM1)	I/O	0	100	100	integer	Adjustment in %
75	74	BMS_address	Device address for BMS communication	O	0	256	1	integer	
76	75	-	-	-	-	-	-	-	
77	76	BMS_change_en	BMS settings change	O	0	1	1	integer	0 – off, 1 - on
78	77	BMS_START_STOP_en	BMS START_STOP	O	0	1	1	integer	0 – off, 1 - on
79	78	-	-	-	-	-	-	-	
80	79	UID1	UID -characters 1 and 2	O	12336	23130	-	ASCII	
81	80	UID2	UID -characters 3 and 4	O	12336	23130	-	ASCII	
82	81	UID3	UID -characters 5 and 6	O	12336	23130	-	ASCII	
83	82	UID4	UID -characters 7 and 8	O	12336	23130	-	ASCII	
84	83	UID5	UID -characters 9 and 10	O	12336	23130	-	ASCII	
85	84	UID6	UID -characters 11 and 12	O	12336	23130	-	ASCII	
86	85	UID7	UID -characters 13 and 14	O	12336	23130	-	ASCII	
87	86	UID8	UID -characters 15 and 16	O	12336	23130	-	ASCII	
88	87	UID9	UID -characters 17 and 18	O	12336	23130	-	ASCII	
89	88	UID10	UID -characters 19 and 20	O	12336	23130	-	ASCII	
90	89	UID11	UID -characters 21	O	48	90	-	ASCII	Younger byte is a mark, omit older byte
91	90	P1_value	Measured pressure – air supply	O	0	4000	0	integer	Unit: Pa
92	91	P2_value	Measured pressure – exhaust	O	0	4000	0	integer	Unit: Pa
93	92	Flow1_value	Measured flow – air supply	O	0	4000	0	integer	Unit: m3/h
94	93	Flow2_value	Measured flow – exhaust	O	0	4000	0	integer	Unit: m3/h
95	94	P1_setPoint	Preset pressure – air supply	O	0	4000	50	integer	Unit: Pa
96	95	P2_setPoint	Preset pressure – exhaust	O	0	4000	50	integer	Unit: Pa
97	96	Flow1_setPoint	Remote flow – air supply	O	0	4000	50	integer	Unit: m3/h
98	97	Flow2_setPoint	Remote flow – exhaust	O	0	4000	50	integer	Unit: m3/h
99	98	Reg_sett	Control mode	I/O	0	3	0	integer	0 – standard, 1 – constant pressure (COP), 2 – constant air flow (CAV)
100	99	Pressure_W1_USE R1	Preset pressure – air supply – user 1 mode	I/O	0	4000	50	integer	Unit: Pa

101	100	Pressure_W1_USE R2	Preset pressure – air supply – user 2 mode	I/O	0	4000	50	integer	Unit: Pa
102	101	Pressure_W1_USE R3	Preset pressure – air supply – user 3 mode	I/O	0	4000	50	integer	Unit: Pa
103	102	Pressure_W1_USE R4	Preset pressure – air supply – user 4 mode	I/O	0	4000	50	integer	Unit: Pa
104	103	Pressure_W2_USE R1	Preset pressure – exhaust – user 1 mode	I/O	0	4000	50	integer	Unit: Pa
105	104	Pressure_W2_USE R2	Preset pressure – exhaust – user 2 mode	I/O	0	4000	50	integer	Unit: Pa
106	105	Pressure_W2_USE R3	Preset pressure – exhaust – user 3 mode	I/O	0	4000	50	integer	Unit: Pa
107	106	Pressure_W2_USE R4	Preset pressure – exhaust – user 4 mode	I/O	0	4000	50	integer	Unit: Pa
108	107	Flow_W1_USER 1	Preset flow – air supply – user 1 mode	I/O	0	4000	50	integer	Unit: m3/h
109	108	Flow_W1_USER 2	Preset flow – air supply – user 2 mode	I/O	0	4000	50	integer	Unit: m3/h
110	109	Flow_W1_USER 3	Preset flow – air supply – user 3 mode	I/O	0	4000	50	integer	Unit: m3/h
111	110	Flow_W1_USER 4	Preset flow – air supply – user 4 mode	I/O	0	4000	50	integer	Unit: m3/h
112	111	Flow_W2_USER 1	Preset flow – exhaust – user 1 mode	I/O	0	4000	50	integer	Unit: m3/h
113	112	Flow_W2_USER 2	Preset flow – exhaust – user 2 mode	I/O	0	4000	50	integer	Unit: m3/h
114	113	Flow_W2_USER 3	Preset flow – exhaust – user 3 mode	I/O	0	4000	50	integer	Unit: m3/h
115	114	Flow_W2_USER 4	Preset flow – exhaust – user 4 mode	I/O	0	4000	50	integer	Unit: m3/h
116	115	k_fac_W1	Air supply fan k coefficient	I/O	0	1000	0	float	
117	116	k_fac_W2	Exhaust fan k coefficient	I/O	0	1000	0	float	
118	117	PSA_W1	Air supply fan start level	I/O	dyn. (25)	dyn. (100)	30	integer	Adjustment in %
119	118	PSA_W2	Exhaust fan start level	I/O	dyn. (25)	dyn. (100)	30	integer	Adjustment in %
120	119	maxPres_AIN1	Max. Air supply pressure – analog sensor	I/O	0	4000	100	integer	Unit: Pa
121	120	maxPres_AIN2	Max. Exhaust pressure – analog sensor	I/O	0	4000	100	integer	Unit: Pa

List of BMS alarms

BMS Index	Modbus address	Variable name	Description	Signal type	Signal type			Variable type	Comments
					Min.	Max.	Dom.		
122	200	FAS_AL	FAS alarm	O	0	1	0	integer	0 – inactive, 1 – active
123	201	Service_AL	General inspection required	O	0	1	0	integer	0 – inactive, 1 – active
124	202	Filter_AL	Filter replacement required	O	0	1	0	integer	0 – inactive, 1 – active
125	203	Filter_AL_SUP	Air supply dirty filter – pressure switch action	O	0	1	0	integer	0 – inactive, 1 – active
126	204	Filter_AL_EXH	Exhaust dirty filter – pressure switch action	O	0	1	0	integer	0 – inactive, 1 – active
127	205	Sensor_T2_AL	Sensor T2 malfunction	O	0	1	0	integer	0 – inactive, 1 – active
128	206	Sensor_T3_AL	Sensor T3 malfunction	O	0	1	0	integer	0 – inactive, 1 – active
129	207	Sensor_T4_AL	Sensor T4 malfunction	O	0	1	0	integer	0 – inactive, 1 – active
130	208	Sensor_T5_AL	Sensor T5 malfunction	O	0	1	0	integer	0 – inactive, 1 – active
131	209	Sensor_T6_AL	Sensor T6 malfunction	O	0	1	0	integer	0 – inactive, 1 – active
132	210	Sensor_T1_AL	Sensor T1 malfunction	O	0	1	0	integer	0 – inactive, 1 – active
133	211	-	-	-	-	-	-	-	-
134	212	sup_HT_AL	Air supply high temperature	O	0	1	0	integer	0 – inactive, 1 – active
135	213	sup_LT_AL	Air supply low temperature	O	0	1	0	integer	0 – inactive, 1 – active
136	214	Hex_frost_AL	Frosted exchanger	O	0	1	0	integer	0 – inactive, 1 – active
137	215	N1_HT_temp_AL	Possible primary heater overheat	O	0	1	0	integer	0 – inactive, 1 – active
138	216	N2_HT_temp_AL	Possible secondary heater overheat	O	0	1	0	integer	0 – inactive, 1 – active
139	217	N1_HT_AL	Electric primary heater overheat	O	0	1	0	integer	0 – inactive, 1 – active
140	218	N2_HT_AL	Electric secondary heater overheat	O	0	1	0	integer	0 – inactive, 1 – active
141	219	Frost_AL	Activation of soaking process for secondary heater	O	0	1	0	integer	0 – inactive, 1 – active



Parameter type: O – only Output – read only parameter, I/O – Input/Output – read and modification allowed.

9.17. Installer menu - structure



The menu is available after entering the service password. Depending on controller configuration and whether it is on or off, some of menu parameters might be unavailable. These are marked with “*”.

Service configuration confirmation

Information

Filters settings*

- Dirt det. mechanism - supply*
 - None, Time, Pressure switch, Transducer
- Dirt det. mechanism - exhaust*
 - None, Time, Pressure switch, Transducer
- Signal source selection*
- Filter classes parameters*
 - Standard class
 - Filter class
 - Initial resistance
 - Final resistance
 - Alarm when dirty
 - VENTILATION SYSTEM emergency mode
 - Medium class (arrangement as above)
 - Fine class (arrangement as above)
 - Filter classes default settings
- Detection mechanism*
 - Time mechanism*
 - Days to alarm
 - Days to emergency mode
 - Detection by pressure switches*
 - Logical state filter supply
 - Logical state filter exhaust
 - Supply air filter used-up alarm
 - Supply filter lifetime
 - Enabling emergency mode of supply filter
 - Exhaust filter used-up alarm
 - Exhaust filter lifetime
 - Enabling emergency mode - exhaust filter
 - AIN max. value of pressure difference supply*
 - AIN max. value of pressure difference exhaust*
 - Filters test delay*
 - Pollution test adjustment*
- Filters support*
 - Force filters replacement procedure
 - Filters replacement by user
 - Supply filter worktime reset
 - Exhaust filter worktime reset
 - Emergency mode – system stopped
 - Emergency mode - supply fan*
 - Emergency mode - exhaust fan*
 - Pollution test frequency
 - Pollution test start day
 - Force pollution test

Manual control

Air supply and exhaust control

- Type of regulation:
- Standard, Constant pressure, Constant flow

Bypass setting

- Bypass support:
- Yes, No
- Control mode
- Smooth, Digital
- Minimum control
- Maximum control
- Kp setting
- Ki setting
- Td setting
- Actuator full opening time

GHE/Mix. chamber/Cooler settings*

- GHE support*
Yes/No
- Mixing chamber support*
Yes/No
- Cooler support*
Yes/No
- GHE temp. Sensor*
Yes/No

Heaters settings

- Secondary heater type*
None, Electric (ON / OFF), Electric (0-100%), Water (ON / OFF), Water (0-100%)
- Primary heater type*
None, Electric (ON / OFF), Electric (0-100%), Water (ON / OFF), Water (0-100%)
- Thermostats of heaters*
Normally open, Normally closed
- Primary heater thermostat*
Normally open, Normally closed
- Secondary heater thermostat*
Normally open, Normally closed
- Primary heater control mode
Normal, SSR
- Secondary heater control mode
Normal, SSR
- Min. supply control with secondary heater*
- Min. supply control with primary heater*
- Primary heater without defrosting
Yes, No
- Heater activation temp.*
- Heater deactivation hysteresis*

Air quality sensors settings*

- Analog CO2 sensor*
- CO2 sensor support
 - Normal CO2 concentration
 - CO2 concentration hysteresis
 - CO2 sensor range
 - Fans adjustment change
- Analog humidity sensor*
- Humidity sensor support
 - Normal humidity level
 - Humidity level hysteresis
 - Fans adjustment change

CO2 threshold sensor*
<ul style="list-style-type: none"> • CO2 sensor support • Sensor logical state • Fans speed • Maintenance time
Threshold humidity sensor*
<ul style="list-style-type: none"> • Humidity sensor support • Sensor logical state • Fans speed • Backup time

Hood mode settings*
IN1 logical state*
<ul style="list-style-type: none"> • Normally Open Normally Closed
IN2 logical state*
<ul style="list-style-type: none"> • Normally Open Normally Closed
Supply fan control by IN1*
Exhaust fan control by IN1*
Supply fan control by IN2*
Exhaust fan control by IN2*

Inspection/blockade settings
Inspection function support
Device blockade support
Inspection counter reset
Days till inspection
Day till blockade

UExchanger dehydration settings
Periodical dehydration
Dehydration work time

Exchanger cleaning settings*
Manual cleaning start
Stage 1 duration
Stage 2 duration
Cleaning schedule (days)

Fans settings
Min. supply fan control
Max. supply fan control
Min. exhaust fan control
Max. exhaust fan control
Supply fan stop delay*
Exhaust fan stop delay*
Min. outside temp.
<ul style="list-style-type: none"> • Perm. from min. outside temp. • Min. outside temp. • Min. outside temp. hysteresis
Supply fan start delay
Exhaust fan start delay
Fans operation control*
<ul style="list-style-type: none"> • Supply fan • Exhaust fan

Modbus settings
Modbus address
Transmission speed
<ul style="list-style-type: none"> • 9600, 19200, 115200
Stop bits amount
<ul style="list-style-type: none"> • 1 stop bit, 2 stop bits
Parity
<ul style="list-style-type: none"> • None, Even, Odd
Modbus activation
<ul style="list-style-type: none"> • Yes, No

Edit parameters
<ul style="list-style-type: none"> • Yes, No
Ventilation system control
<ul style="list-style-type: none"> • Yes, No

Default settings
Default setting panel
Default setting service
Default setting client

Save/Load configuration	
ecoTOUCH	VER-AHP

Touch panel calibration

Address settings

ecoPRESS settings
ecoPRESS support
Number of ecoPRESS sensors*
Serial numbers configuration*
<ul style="list-style-type: none"> • ecoPRESS 1 serial number • ecoPRESS 2 serial number* • ecoPRESS 3 serial number* • ecoPRESS 4 serial number* • Sensors addressing
Nulling / Transmission of ecoPRESS sensors*
<ul style="list-style-type: none"> • Nulling ecoPRESS 1 sensor • Nulling ecoPRESS 2 sensor* • Nulling ecoPRESS 3 sensor* • Nullung ecoPRESS 4 sensor* • ecoPRESS sensors - transmission

9.18. Manufacturer menu - structure



The menu is available after entering the service password. Depending on controller configuration and whether it is on or off, some of menu parameters might be unavailable. These are marked with “*”.

Confirm service configuration

Air supply and exhaust control
Signal source selection
Air supply control
<ul style="list-style-type: none"> • AIN sensor processing range • Flow K coefficient • Start level
Exhaust control
<ul style="list-style-type: none"> • AIN sensor processing range • Flow K coefficient • Start level

Rotary exchanger settings*
Exchanger motor control
<ul style="list-style-type: none"> • Yes, No
Control type
<ul style="list-style-type: none"> • Smooth, Digital
Minimum control
Maximum maksymalne
Kp setting
Ki setting

Td setting

Primary heater settings

Heater Kp settings
Heater Ki settings
Heater Td settings
Min. control value
Max. control value

Secondary heater settings

Heater Kp settings
Heater Ki settings
Heater Td settings
Start delay
Actuator full open time

Cooler settings

Cooler Kp settings
Cooler Ki settings
Cooler Td settings
Actuator full opening time
Cooler blockade time

Mixing chamber settings

Kp setting
Ki settings
Td settings
Mixing chamber min. control
Mixing chamber max. control

Exchanger anti-freezing

Exchanger defrosting support
• On, Off
Ventilation default settings use*
• Dedicated, Operation mode
Use primary heater
• Yes, No
Defrosting turn on temp.
Defrosting turn off hysteresis
Air supply fan adjustment
Exhaust fan adjustment
Minimum air supply fan control
Air supply fan speed change
• Yes, No

Air supply temperature protection

Protection against too high temp.
• No, Alarm and turn off, Turn off secondary heater
Air supply temperature limit value
Operation pause duration
Protection against too low temp.
• No, Alarm and turn off, Turn off secondary heater
Low supply temp. threshold
Detection time of low temp.

Exchanger cleaning settings

Exchanger cleaning support
• Off, On

Filters settings

Dirtying detection mechanism – air supply:

- None, Time, Pressure switch, Sensor

Dirtying detection mechanism – exhaust:

- None, Time, Pressure switch, Sensor

Signal source selection

Configured by installer

Filters replacement:

- Installer, User, Configured by installer

Functions available for installer:

- Filter classes parameters
- Time mechanism
- Detection by pressure switches
- Differential pressure sensors
- Dirtying test delay
- Dirtying test adjustment

Filter classes parameters:

- Standard class:
 - Filter class
 - Initial resistance
 - Final resistance
 - Dirt alarm
 - Central emergency mode
- Medium class (as above)
- Accurate class (as above)
- Filter classes default settings (yes/no)

Detection mechanism

- Time mechanism
 - Days till alarm
 - Days till emergency mode
- Detection with pressure switches
 - Logical state air supply filter
 - Logical state exhaust filter
 - Wear of air supply filter alarm
 - Air supply filter life
 - Air supply filter emergency mode turn on
 - Wear of exhaust filter alarm
 - Exhaust filter life
 - Exhaust filter emergency mode turn on
- AIN max. value of pressure difference
Air supply
- AIN max. value of pressure difference
exhaust
- Filters test delay
- Filters dirty test adjustment

Filters support

- Override filters replacement procedure
- Filters replacement by user
- Reset air supply filter operation time
- Reset exhaust filter operation time
- Emergency mode – central stop
- Emergency mode – air supply fan
- Emergency mode – exhaust fan
- Dirtying test frequency
- Test starting day
- Dirtying test starting hour
- Override dirtying test

Inputs/outputs settings*

Inputs configuration

- Changing analog inputs
- AIN1...AIN2
- Empty, Humidity sensor, CO2

sensor, Air supply pressure sensor, Exhaust pressure sensor, Air supply filter detection, Exhaust filter detection.

- Changing digital inputs
 - DIN1...DIN5
 - None, Primary heater thermostat, Secondary heater thermostat, Thermostats, Alarm central, FAS alarm, Relative humidity sensor, CO2 sensor, R1 input, R2 input, Air supply duct filter, Exhaust duct filter, Air supply ventilation control, Exhaust ventilation control.
- Changing internal inputs
 - DP1...DP2
 - None, Air supply control, Exhaust control, Detection filter air supply, Detection filter exhaust.

Outputs configuration

- Changing relay outputs
 - OUT1...OUT3 (+230VAC)
 - REL1...REL3 (potentialfree)
 - Free, Air supply fan, Exhaust fan, Bypass, Rotary exchanger, Secondary heater, Primary heater, GHE, Cooler, Shut off throttle, Central OPERATION, Central ALARM, Heater mixer ON, Heater mixer OFF, Cooler mixer ON, Cooler mixer OFF, Bypass mixer ON, Bypass mixer OFF
- Changing analog outputs
 - AOUT1...AOUT4
 - None, Air supply fan, Exhaust fan, Bypass / Rotary exchanger, Cooler, Secondary heater, Mixing chamber actuator, Primary heater
- Control change 0 – 10 V
 - AOUT1...AOUT4
 - Control: Normal, Inverted
 - Minimum voltage
 - Maximum voltage
- Central operation signal – mode
 - None, Fans, Mode 1, Mode 2, Mode 3, Mode 4, Pause mode, Party mode, Airing mode, Out mode, Leading sensor, Primary heater thermostat, Secondary heater thermostat

9.18.1. Menu - Unlock the device



Menu available only after entering a special password.

Unlocking device
Device blockade
Reset blockade counter
Device unlocking

Temp. sensor behind exchanger

- Yes, No

ecoNET support

- Yes, No

Default settings

- Default setting panel
- Default setting service
- Default setting client
- Counters erase

9.19. Description of the installer parameters

Configuration confirmation service	After changing service settings a correct controller configuration must be confirmed to allow its further operation, according to section 9.20.15.
Filters settings	Settings related to mechanisms monitoring filters dirtying status.
Manual control	Manual mode allows to set individual relay outputs manually. Attention: This menu must be used with caution and knowingly switch on the outputs to prevent damaging the ventilation system.
Air supply and exhaust control	Control mode settings for fans: air supply and exhaust
Control type	Selection of air supply and exhaust smooth control: - Standard – no automatic fans speed regulation. Fans adjustment is possible only by changing active operation modes or its settings. - Constant pressure – (COP) fans speed regulation to keep the constant pressure in ducts air supply and exhaust. Differential pressure sensors required. - Constant flow – (CAV) fans speed regulation to keep constant flow in ducts: air supply and exhaust. Differential pressure sensors required.
Bypass settings	Bypass settings related to smooth bypass throttle control and bypass2 throttle control.
Bypass support	Option to turn on bypass support in device.
Control mode	Setting the bypass throttle control mode: Digital - digital or analog.
Minimum bypass control	Setting minimum control for bypass throttle with PID control.
Maximum control	Setting maximum control for bypass throttle with PID control.
Kp settings	Setting amplification of the PID algorithm for bypass control.
Ki settings	Setting integration of the PID algorithm for bypass control.
Td settings	Setting differentiation of the PID algorithm for bypass control.
Actuator full opening time	Time to full open of mixer actuator.
GHE/mixing chamber/cooler settings	Menu contains parameters allowing turn on or off the support for individual functional modules of the system.
GHE support	Turning on or off GHE control module. If GHE is not available in the system, the system should be turned off to prevent disturbances in regulation algorithms operation.
Mixing chamber support	Turning on or off mixing chamber support..
Cooler support	Turning on or off cooler support.
GHE sensor	Turning on or off additional GHE sensor support.
Fans settings	Menu contains fans settings available for installer, where minimum and maximum fans adjustment values are set and delays of stopping fans after electric heaters operation.
Min. air supply fan control	Minimum adjustment that can be set in used air supply fan. Setting must be adjusted depending on fans power.
Max. air supply fan control	Maximum control that can be set in used air supply fan. Setting must be adjusted depending on fans power.
Min. exhaust fan control	Minimum control that can be set in used air supply fan. Setting must be adjusted depending on fans power.
Max. exhaust fan control	Maximum control that can be set in used air supply fan. Setting must be adjusted depending on fans power.
Air supply fan stop delay	Air supply fan stop delay after stopping operation of electric heater
Exhaust fan stop delay	Exhaust fan stop delay after stopping operation of electric heater.
Minimum external temperature	Menu contains settings related to mechanism allowing operation from minimum temperature.
<ul style="list-style-type: none"> Allow from min. external temp. 	Parameter allowing turn on/off mechanism allowing operation from minimum external temperature. Below this threshold fans will be stopped and throttles closed.
<ul style="list-style-type: none"> Min. external temp. 	Parameter allows determining minimum external temperature, below which the system will be disabled.
<ul style="list-style-type: none"> Min. external temp. hysteresis 	Parameter allows determining external temperature hysteresis; exceeding it allows system to resume operation.
Air supply fan start delay	Air supply fan start delay after entering into Operation mode from Off mode waiting for throttles to open.
Exhaust fan start delay	Exhaust fan start delay after entering into Operation mode from Off mode waiting for throttles to open.

Fans operation control	Menu contains settings related to fans operation control function.
<ul style="list-style-type: none"> Air supply fan 	Parameter allows setting normal status of digital input to confirm operation of air supply fan.
<ul style="list-style-type: none"> Exhaust fan 	Parameter allows setting normal status of digital input to confirm operation of exhaust fan.
Heaters settings	Setting related to primary and secondary heaters.
Secondary heater type	Selection of supported secondary electric heater type.
Primary heater type	Parameter allows setting normal status of digital input to detect signal from primary heater thermostat (electric or water).
Secondary heater thermostat	Parameter allows setting normal status of digital input to detect signal from secondary heater thermostat (electric or water).
Termostaty nagrzewnic	Parametr pozwala ustawić normalny stan wejścia dwustanowego do detekcji sygnału od połączonych (szeregowo) termostatów nagrzewnic tych samych typów.
Heaters thermostats	Parameter allows setting normal status of digital input to detect signal from connected (serial) thermostats of heaters of the same type.
Primary heater control mode	Parameter allows setting control mode of primary heater. Normal mode f = 6 kHz; SSR mode f = 0.1 Hz.
Secondary heater control mode	Parameter allows setting control mode of secondary heater. Normal mode f = 6 kHz; SSR mode f = 0.1 Hz.
Primary heater beyond defrosting	Turn off/on primary heater beyond defrosting.
Heater switching on temp.	Threshold to activate primary heater beyond defrosting.
Heater switch off hysteresis	Turn off primary heater beyond defrosting hysteresis.
Air quality parameters sensor settings	Settings related to threshold and analog air quality parameters sensors.
Analog CO2 sensor	Menu contains settings related to analog CO2 sensor
<ul style="list-style-type: none"> CO2 sensor support 	Parameter allowing turning on/off analog CO2 sensor support.
<ul style="list-style-type: none"> CO2 normal concentration 	Parameter allows to determine level of CO2 read by regulation algorithm as normal.
<ul style="list-style-type: none"> CO2 concentration hysteresis 	Parameter allows to determine concentration range of CO2 in the air, treated as normal.
<ul style="list-style-type: none"> CO2 sensor range 	Parameter for regulation algorithms, keeps information of measuring range of used CO2 sensor.
<ul style="list-style-type: none"> Fans speed change 	Parameter allows to determine percentage speed change of fans in case of detecting too high CO2 level in the air.
Analog humidity sensor	Menu contains settings related to support of analog humidity sensor.
<ul style="list-style-type: none"> Humidity sensor support 	Parameter allows turning on/off analog humidity sensor support.
<ul style="list-style-type: none"> Normal humidity level 	Parameter allows to determine humidity level read by regulation algorithm as normal.
<ul style="list-style-type: none"> Humidity level hysteresis 	Parameter allows to determine air humidity range treated as normal.
<ul style="list-style-type: none"> Fans speed change 	Parameter allows to determine percentage speed change of fans in case of detecting too low or too high air humidity level.
CO2 threshold sensor	Menu contains settings related to threshold CO2 sensor support.
<ul style="list-style-type: none"> CO2 sensor support 	Parameter allows turning on/off threshold CO2 sensor support.
<ul style="list-style-type: none"> Sensor logical state 	Parameter allows to determine normal status of contact for detection of signals from threshold CO2 sensor.
<ul style="list-style-type: none"> Fans speed 	Parameter allows to determine fans speed to be set after detecting signal from threshold CO2 sensor.
<ul style="list-style-type: none"> Backup time 	Parameter allows to determine backup time of changed settings after stopping signal from threshold CO2 sensor.
Humidity threshold sensor	Menu contains settings related to threshold humidity sensor support.
<ul style="list-style-type: none"> Humidity sensor support 	Parameter allows turning on/off threshold humidity sensors support.
<ul style="list-style-type: none"> Sensor logical state 	Parameter allows to determine normal status of contact for detection of signals from threshold humidity sensor.
<ul style="list-style-type: none"> Fans speed 	Parameter allows to determine fans speed to be set after detecting signal from threshold humidity sensor.
<ul style="list-style-type: none"> Backup time 	Parameter allows to determine backup time of changed fans settings after stopping signal from threshold humidity sensor.

Hood mode settings	Menu contains settings related to hood mode.
Logical state IN1	Parameter allows setting normal digital input status to detect IN1 signal for hood mode.
Logical state IN2	Parameter allows setting normal digital input status to detect IN2 signal for hood mode
Supply air fan control with IN1	Setting percentage adjustment change of air supply fan for IN1 signal. Setting value above zero increases adjustment, below zero decreases adjustment.
Exhaust fan control with IN1	Setting percentage adjustment change of exhaust fan for IN1 signal. Setting value above zero

	increases adjustment, below zero decreases adjustment.
Supply air fan control with IN2	Setting percentage adjustment change of air supply fan for IN2 signal. Setting value above zero increases adjustment, below zero decreases adjustment.
Exhaust fan control with IN2	Setting percentage adjustment change of exhaust fan for IN2 signal. Setting value above zero increases adjustment, below zero decreases adjustment.
Inspection / Blockade settings	Settings related to turning on/off general inspection support and ventilation system operation blockade.
Inspection functions support	Turning on/off prompts of periodical inspection.
Device operation blockade support	Turning on/off operation blockade of ventilation system.
Reset inspection counter	Resetting counter for periodical inspection to start counting time anew till next inspection.
Days till inspection	Setting number of days till reporting information about necessity of periodical inspection.
Days till blockade	Number of days till device operation blockade after which the device operation will be blocked.
Exchanger dehydration settings	Settings related to exchanger dehydration function. Exchanger dehydration is to drain water from the inside the exchanger by stopping air supply and exhaust fan operation, which allows water to flow freely.
Periodical dehydration	Setting by how many hours exchanger dehydration function is to start. Setting "0" turns off dehydration function.
Dehydration operation mode	Duration time of exchanger dehydration procedure. During this procedure fans operation is stopped.
Exchanger cleaning settings	Setting related to exchanger cleaning.
Manual cleaning start	External temperature below which fans speed will be decreased or increased.
Stage 1 duration time	Duration time of stage 1 cleaning where W1 fan stops and W2 fan works at 100% of power.
Stage 2 duration time	Duration time of stage 2 cleaning where W2 fan stops and W1 fan works at 100% of power.
By how many days start	Setting by how many days exchanger cleaning is to start.
Modbus settings	Settings related to Modbus communication. Modbus address, desired Transmission speed (9600, 19200, 115200), Number of stop bits and Parity must be set.
Modbus address	Settings related to Modbus address.
Transmission speed	Transmission speed for Modbus communication.
Stop bits number	Settings related to number of stop bits.
Parity	Settings related to parity.
Modbus activation	Turning on/off Modbus protocol support.
Parameters edit	Allowing parameters edit via Modbus protocol.
Ventilation system controlling	Allowing Modbus to control ventilation system.
Default settings	Menu contains parameters allowing resetting to default settings of panel, User and Installer.
Default settings Panel	Parameter allows reset panel to default settings.
Default settings User	Parameter allows to reset all parameters in the menu enabled for end-user to default settings.
Default settings service	Parameter allows to reset all parameters in the Installer menu to default settings

Configuration Save / Load	Menu allows to read configuration data of the device and/or overwrite its current configuration.
Touch panel calibration	Selecting this option allows touch panel calibration.
Address settings	Parameter allows setting ecoTOUCH panel address on the bus. Attention! For proper system operation individual room panels must have set different addresses from the pool 100...132.
ecoPRESS settings	Menu allows configuration of external ecoPRESS modules connected to COM2 input.
ecoPRESS support	Parameter allows turning on/off a module supporting communication with ecoPRESS via COM2 port.
ecoPRESS sensors number	Setting number of measuring modules connected to the controller via COM2.
Serial numbers configuration	Menu allows to input serial numbers and conducting addressing procedure of sensors for proper calibration of connection with the controller.
Nulling / Transmission of ecoPRESS sensors	Menu allows nulling ecoPRESS sensors and changing transmission speed on main line.

9.20. Outputs configuration and confirmation of configuration

The controller allows configuration of active functions on relay outputs and analog outputs.



Before making the electric connection of outputs, make sure that their configuration is correct.

9.20.1. Heaters

The controller has function to control heaters: primary and secondary. To configure this function first select outputs to control the heater and outputs to monitor heaters operation status. Settings related to inputs and outputs support are in Inputs/outputs settings menu.



The controller allows control over three-point mixing valve of water heater circuit. To start three-point control on two selected relay outputs the following parameters must be set: Heater mixer ON in first output, Heater mixer OFF in second output. In case of setting only one output three-point control function will not be active.

In Relay outputs configuration menu chose and set relay outputs for secondary and primary heater control. Using Relay outputs change parameters a proper relay output to control configured heater can be set. Using Analog outputs change parameter setting source of signal modulating heater operation can be done. After setting outputs controlling heater enter Inputs configuration menu and using Digital inputs change parameters set a contact used to monitor primary and secondary heater thermostat status.



No or improper configuration of inputs for monitoring heaters thermostats status can cause improper operation of ventilation system.

After configuration control signals controlling primary and secondary heater, additional parameters shall appear in the menu to fully configure heater control function. In Secondary heater settings and Primary heater settings menu the following can be set: PID algorithm controlling heater settings, start delay time and time to mixer full opening (parameter used only with three-point control).



Improper setting heater support parameters may cause malfunction or lower heating comfort in ventilated rooms.

From the level of Heaters settings menu, Installer can define: heater type, normal status of contact monitoring signal from thermostat, modulation mode of heater operation and (for electric heater) minimum air supply fan control allowing heater to start. If control function is properly configured in Information menu, under Heaters section parameters with information on heaters current status shall appear.

9.20.2. Cooler

The controller has function to control cooler. Function configuration begins with selecting outputs to control cooler. Settings related to inputs and outputs are in Inputs/outputs settings menu.



The controller allows control over three-point mixing valve of water cooler circuit. To start three-point control on two selected relay outputs the following parameters must be set: Cooler mixer ON in first output, Cooler mixer OFF in second output. In case of setting only one output three-point control function will not be active.

In Relay outputs menu select and set relay output for cooler control. In Analog outputs change menu source of modulating signal is set. After configuration of cooler control signals additional parameters for full configuration of cooler control function shall appear. In Cooler settings menu the following shall be set: PID algorithm controlling cooler settings, mixer full opening time (used only with three-point control) and cooler operation blockade time with open bypass throttle.



Improper setting cooler support parameters may cause malfunction or lower heating comfort in ventilated rooms.

Installer using Cooler support parameter can enable algorithm controlling cooler. If cooler support is properly configured and its control algorithm is on, parameters with information on current cooler operation status shall appear in Information menu under Bypass throttles / Mixing chamber / Cooler section.

9.20.3. GHE

The controller has function to control Ground Heat Exchanger. Its configuration starts with selecting output to control GHE throttle. In Inputs/outputs settings menu, using Relay outputs change parameters, set relay output for controlling GHE throttle.

Installer with GHE support parameter can enable GHE throttle control algorithm. If configuration of GHE support is done properly parameters with information on current throttle operation status shall appear in Information menu, under Ground Heat Exchanger section.

9.20.4. By-pass

The controller has bypass control function. Its configuration starts with selecting outputs to control its throttle. Settings related to inputs and outputs support are in Inputs/outputs settings menu.



The controller allows three-point bypass throttle control. To start three-point control on two selected relay outputs the following parameters must be set: Bypass mixer ON in first output, Bypass mixer OFF in second output. In case of setting only one output three-point control function will not be active.

In Relay outputs change a relay output to control bypass can be selected. In Analog outputs change a source of modulating signal can be selected. After configuration of control signals Bypass settings menu shall be displayed, used for full bypass configuration and allowing to: switch on algorithm and selection of throttle control, selection of PID algorithm settings, limiting control range and declaration of duration of mixer full opening (used only with three-point control).



Improper bypass setting can decrease recovery and lower heating comfort.

If bypass throttle control is configured properly, parameters with information on current throttle operation status shall appear in Information menu, under Bypass throttles / Mixing chamber / Cooler section.

9.20.5. Rotary exchanger

The controller has rotary exchanger control function. This function configuration starts with selecting outputs used to control exchanger motor. Settings related to inputs and outputs support are in Inputs/outputs settings menu. In Relay outputs change select and set a relay output controlling the exchanger. In Analog outputs change select source of modulating signal. After configuration of control signals Rotary exchanger settings menu shall be displayed, used for full configuration of motor control with parameters allowing switching on the algorithm and selecting control type of the motor, selecting PID algorithm settings and limiting control range.



Improper selection of rotary exchanger settings may decrease recovery and lower heating comfort.

If rotary exchanger motor control is configured properly in Information menu, under Bypass throttles / Mixing chamber / Cooler section, parameters with information on current exchanger operation status shall appear. .

9.20.6. Mixing chamber

The controller has function of controlling mixing chamber throttle. Configuration starts with selecting the output to control mixing chamber throttle. In Inputs/outputs settings, using Analog outputs change parameters set analog output 0 – 10 V to control mixing chamber. After configuration of mixing chamber control signals a menu for full configuration of mixing chamber throttle shall be displayed. In Mixing chamber settings PID algorithm, controlling mixing chamber throttle and its control ranges, settings can be set.



Configuration method of the controller depends on the type of fan convector connected. For bistate fan convector signal set relay output to Fan convector OPERATION, for mode selection signal to Fan convector HEATING/COOLING. If fan convector has separate signals implementing heating and cooling modes, then first should be assigned to Heater output and the second one assigned to Cooler output.

In Inputs configuration contacts for monitoring return signals from fan convector must be set with Digital inputs change parameters.



No or improper configuration of inputs for monitoring of return signals from fan convector may prevent ventilation system from proper operation.



For detection of alarm signal from fan convector a bistate input implementing secondary heater thermostat function can be used. In such situation reaction to alarm signal will directly depend on further configuration steps.

After setting control signals parameters used for full fan convector configuration shall be displayed. Cooler settings menu is used to set factory convector operation in cooling mode. Secondary heater settings menu is used to set factory convector operation in heating mode.



Improper fan convector settings may cause its malfunction or lower heating comfort in ventilated rooms.

Two-step launch of algorithm controlling fan convector by the Installer: First step is to switch on cooling algorithm by switching on cooler support in GHE settings / Mixing chamber / Cooler menu. Second step is to launch heating algorithm, in Heaters settings menu switch on heater support and set normal status for the contact monitoring signal from thermostat. Depending on preset heater mode Electric (0 – 100%) or Water (0 – 100%) a desirable reaction of controller to alarm signal of fan convector or turning fan convector off or turning on fans will be obtained. With fan convector configured properly in Information menu Fan convector heating – cooling section shall appear, containing parameters with information on current operation status of fan convector.

9.20.7. CO2 and humidity threshold sensors

The controller allows cooperation with air parameters threshold sensor – both CO2 and humidity. To configure this function, first select input for signal detection from sensor. In Inputs/outputs settings, using Digital inputs change parameters, select digital input used for signal detection from sensor – Relative humidity sensor or CO2 sensor option. Installer, from the level of Air parameters sensor settings menu, has the ability to enable declared digital sensor and configure its operation. With properly configured sensor and its support enabled Air parameters threshold sensor section shall appear in Information menu, containing parameters with information on current status of sensor operation.

9.20.8. Analog CO2 and humidity sensors

The controller allows cooperation with analog air parameters sensors – both CO2 and humidity. To configure this function, first select analog input used for detection of signal from selected sensor. In Inputs/outputs settings, using Digital inputs change select input used for detection of signal from sensor – Humidity sensor or CO2 sensor. Installer, from the level of Air parameters sensor settings menu has ability to enable support of declared analog sensor and configuration of its operation (define processing ranges, normal concentration range and change fans adjustment settings when concentration is exceeded). With properly configured sensor and its support enabled, Air parameters sensor section shall appear in Information menu, containing parameters with information on current status of sensor operation.

9.20.9. Signal from external central system

The controller allows overriding operation mode depending on external signal from the central system (ECO mode). To configure this function, first select input used for detection of ECO signal. In Inputs/outputs settings, using Digital inputs change parameters select digital input for detection of ECO signal – Alarm central option. With proper configuration in Information menu, under Digital inputs 2 section, parameters with information on current ECO central system shall appear.

9.20.10. Hood mode

The controller allows overriding fans settings depending on external signal (Hood mode). To configure this function, first select inputs to detect signals of hood mode. In Inputs/outputs settings, using parameters in Digital inputs change select digital inputs/outputs used for detection of signal enabling hood mode – Input R1 and/or Input R2 options. Hood mode settings menu allows hood mode configuration. With proper configuration in Information menu, under Digital inputs 1 section, parameters with information on current hood mode status shall appear.

9.20.11. Fans operation confirmation

The controller allows detection of no fans operation using pressure switches monitoring pressure drop. To configure this function, first select input used for detection of signals from pressure switches. In Inputs/outputs settings, using Digital inputs change parameters, select digital inputs to detect signals from pressure switches – Air supply fan control or Exhaust fan control option. Installer from the level of Fans control menu is able to set normal contacts status for monitoring signals confirming fans operation. When this function is properly configured, in the event of no confirmation of fans operation, relevant alarms shall be displayed.

9.20.12. Fire prevention system alarm

Operation of the controller may depend on fire alarm system signal (FAS). To configure this function, first select input used for FAS signal detection. In Inputs/outputs settings, using Digital inputs change parameters, select digital input for FAS detection – FAS alarm option. When properly configured in Information menu, under Digital inputs 2 parameters with information on current status of input monitoring signals from fire protection FAS central shall appear.

9.20.13. Filters dirtying control

The controller has three mechanisms to monitor filters dirtying: based on time mechanism, based on readings from external pressure switches and based on readings from differential pressure sensor. First described mechanism does not require additional inputs configuration or communication paths. To start mechanism monitoring filters dirtying based on pressure switches select inputs for detection of signals from pressure switches. In Inputs/outputs settings, using Digital inputs change parameters, select digital inputs to detect signals from pressure switches – Air supply filter and Exhaust filter option. Starting mechanism monitoring filters dirtying based on external pressure switches is a two-stage procedure. First configure signal source – depending on selected option it can be internal sensors (they should be configured using parameters in Internal inputs change menu placed in Inputs/outputs settings), external sensors processing measured pressure to voltage range 0-10 V (they should be configured using parameters in Analog inputs change menu placed in Inputs/outputs settings) or ecoPRESS-01 sensors (configurable from the level of ecoPRESS settings menu), communicating in RS485 standard.

After initial configuration of functions implemented on inputs and/or ecoPRESS-01 sensors in Filters settings menu Signal source selection option shall be available, using which Installer should indicate a method of connecting pressure differential sensor and in case of communication in RS485 standard, also the address of relevant sensor on the bus for monitoring dirtying.

9.20.14. Fans control modes

The controller controls fans based on one of three strategies: standard control (where fans adjustment is assigned permanently), control with pressure (where rotation speed of fans, are dynamically adjusted to maximally decrease difference between preset and measured differential pressure) and flow control (where rotary speed of fans are dynamically adjusted to maximally decrease differences between flows: preset and measured). Second and third control strategy require additional configuration of the controller. Starting described control strategies is a two-stage procedure. First configure signal source – depending on selected option these can be internal sensors (they should be configured using parameters in Internal inputs change menu placed in Inputs/outputs settings), external sensors processing measured pressure to voltage range 0 – 10 V (they should be configured using parameters with Analog inputs change menu placed in

Inputs/outputs settings) or ecoPRESS-01 sensors (sensors should be connected to COM2 port of the controller and configure them from the level of ecoPRESS settings menu) communicating in RS485 standard. After initial configuration of functions implemented on inputs and/or ecoPRESS-01 sensors enter Air supply and exhaust control menu, within Manufacturer menu and indicate connection method of differential pressure sensors and in case of RS485 standard communication also address of relevant sensors on the bus used to determine pressure differences in the duct. In case of connecting sensors directly to analog inputs define their processing range. If using Constant flow is desired, then additionally correction fans coefficients need to be set. Activation of selected control strategy can be done from the level of Installer menu, in Air supply and exhaust control sub-menu.

9.20.15. Configuration confirmation

After controller configuration is finished, both Installer and Manufacturer, need to confirm propriety of input settings. Confirmation needs to be done by setting Configuration confirmation parameters to Yes.



Without settings confirmation, after starting the controller alarms with ventilation system settings error information will activate. In such situation the device shall remain in pause mode.

9.21. Software update

Software update can be performed using only microSDHC memory card (FAT32, max. 32GB), inserted into the socket in control panel housing.

In order to make software update the controller's power supply must be disconnected. Insert memory card into the indicated socket.

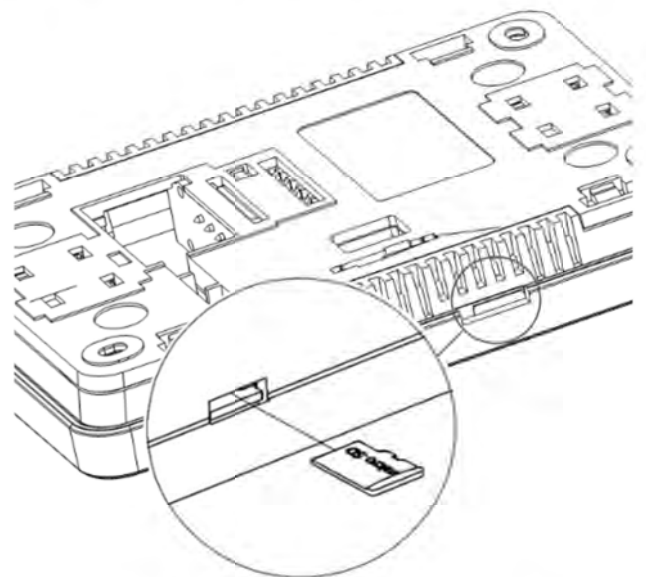

Location of the memory slot in the ecoTOUCH panel.

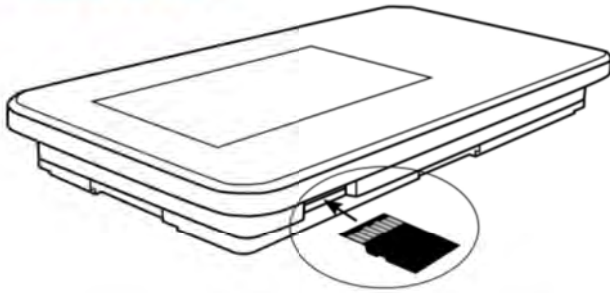

Location of the memory slot in the simTOUCH2 panel.



Before starting controller software update all peripheral devices operating with the central must be disconnected from electric power supply.

The memory card should contain new software in *.pfc format for panel and *.pfi for module. New software should be placed directly on memory card with no folders or sub-folders. Next, connect electric power supply to the controller.

Enter into menu:

Menu → General settings → Software update and install new software, first in main controller module, secondly in control panel.

9.22. Other functions

9.22.1. Unlocking the device

In case of blocking the controller's work, e.g. by unauthorized activation, enter to the menu:

Menu → Service settings enter a special password and unlock the device.

9.22.2. Power supply outage

In case of a power supply outage, the controller recovers to the operation state

before the power outage.

9.22.3. Parts or components replacement

When ordering spare parts and components necessary information placed on their nameplates should be provided. In case of the controller it is essential to know it's serial number. If serial number is unknown its model, type and production date should be provided.

9.22.4. Mains fuse replacement

Use 230 VAC mains fuses, anti-surge fuses, made of porcelain 5 mm x 20 mm. Output circuit fuses should be selected depending on the load. Standard current for the fuse is 6.3 A. A smaller fuse is allowed if the total load on the circuits is lower.

9.22.5. Control panel replacement

When replacing control panel make sure that its software is compatible with software in controller's module. The compatibility is kept if the first number of the software in control panel and module is the same.



Versions of panel and controller software can be read from dedicated parameters under Software version section of Information menu.



No compatibility of panel and controller software may cause unexpected errors. The Manufacturer is not responsible for malfunctions caused as a result of using incompatible software by end-user.

9.22.6. Executive module replacement

Requirements are analogous to the control panel.

Changes record:



The manufacturer reserves a right for making improvements and modifications of the products.

9.23. Controller dimensions

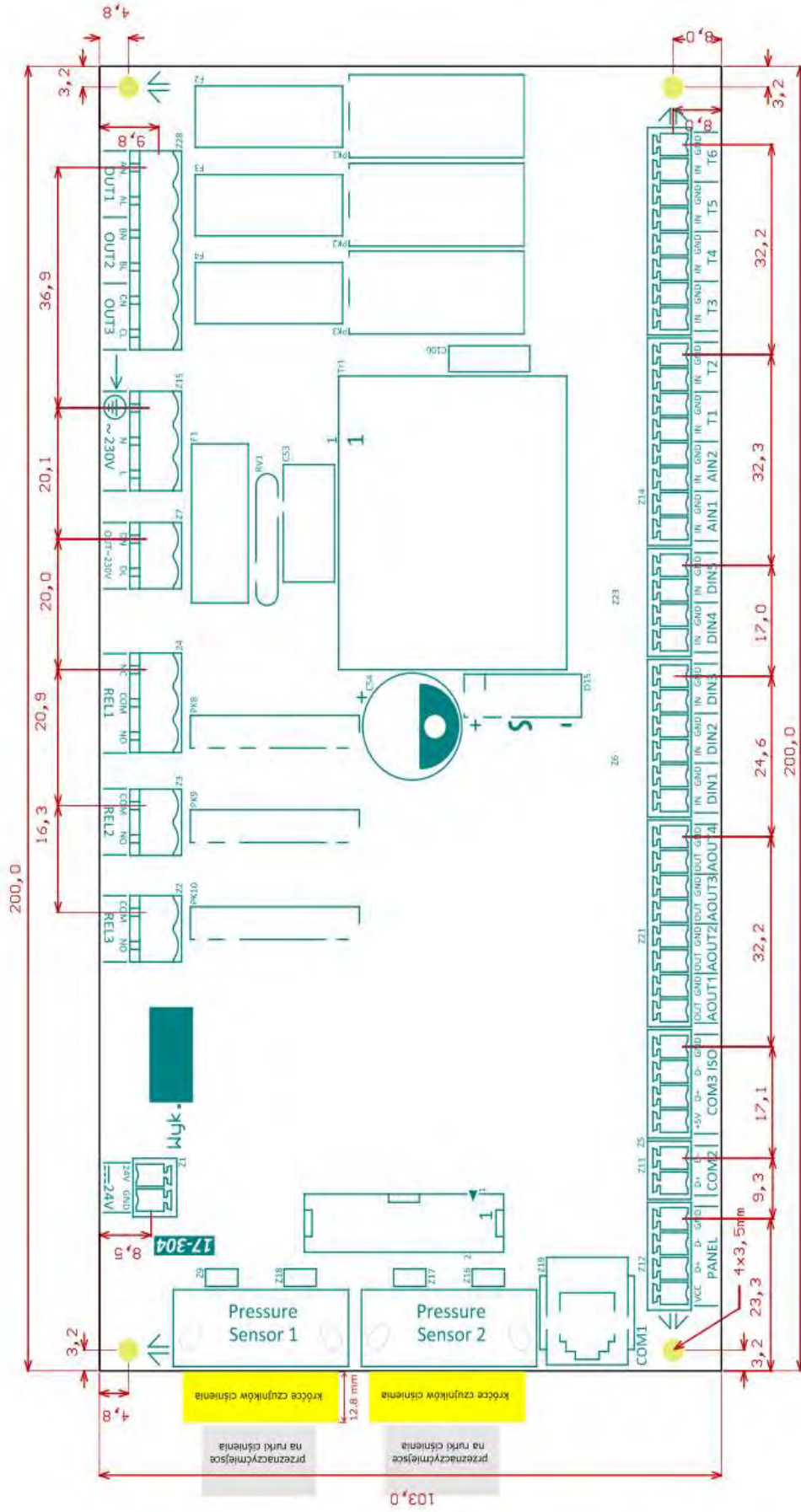

10. Declarations and documents

10.1. Energy labels of devices according to Ecodesign (1253 (1254) / 2014)

VST 400

VSE 250

VSH 400

